

SK7300 FlexStick™ Joystick/ErgoTrac Mouse Encoder with PS/2 and Serial Interface and Ultra Low Power

Sprintek Corporation

FEATURES

- Work with any analog Joystick sensors
- Work with Fujitsu FID-828 ErgoTrac Hall-effect sensors
- Configurable PS/2 and RS-232 interface
- Built-in oscillator, analog and digital circuit
- Advanced motion control algorithm
- Resistor-adjustable motion speed
- Built-in EEPROM to store control parameters and 64 bytes for the host usage
- Compatible with the IBM and Microsoft two-button and the Logitech three-button mouse protocols
- Works with standard Windows® mouse drivers
- Small SSOP 20 pin package: 7.8x7.2mm 2.0 Max (LxWxH)
- Ultra low power consumption. 50uA(idle), 360uA(operation) for 10k analog joystick sensor under 3.3V; 110uA (idle), 1mA (operation) for FID-828 sensor under 5V;
- 2.2V to 5.5V operating voltage
- Industry temperature range: -40°C to +85°C
- QFN package and Extended temperature range (-40°C to +125°C) versions are available upon request

APPLICATION

- Industrial keyboards
- Instrumentation
- Industrial panels

ORDERING INFORMATION

SK7300-PV SSOP 20-pin, 0.65mm pitch, (7.8x7.2mm 2.0 MAX), Pb-Free

DESCRIPTION

The SK7300 joystick mouse encoder is an easy-to-use single chip encoder that interfaces any analog joystick sensors such as CTS252, and Fujitsu FID-828 ErgoTrac Hall-effect sensors. Equipped with an advanced motion algorithm, the SK7300 offers low power consumption in small footprint package. The device can be linked through either the serial or PS/2 type mouse port of the host system.

The SK7300 is compatible with the IBM and Microsoft two-button and the Logitech three-button mouse protocols. The IC also supports Sprintek extended mouse protocols to allow the host to control the motion parameters and other parameters.

Communication through the serial port is half-duplex at a fixed speed of 1200 Baud. PS/2 communication is bidirectional at 10 Kbps. The SK7300 implements all commands to and from the host system, as defined in the IBM PS/2 mouse communication protocol.

Typically, consuming 50uA in idle state, the SK7300 is ideal for battery-operated systems.

PIN ASSIGNMENTS

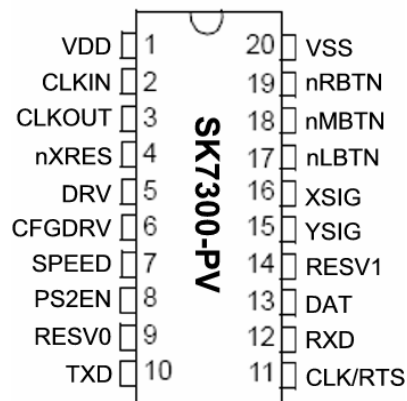

FUNCTION BLOCK DIAGRAM

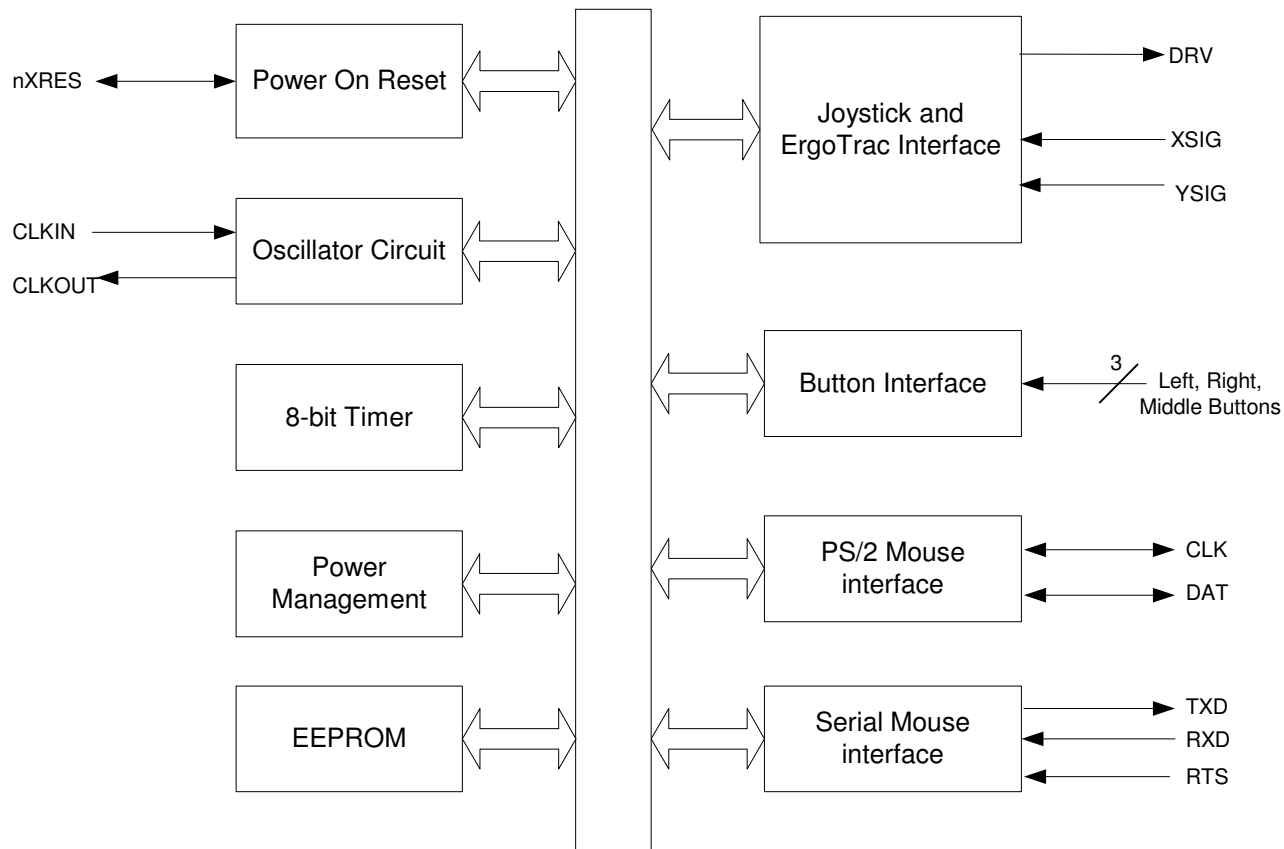

PIN DEFINITION

Pin No	Type	Name	Description
1	P	VDD	Power supply
2	I	CLKIN	Clock in (optional)
3	O	CLKOUT	Clock out (optional)
4	I	nXRES	Active low external reset with internal pull up
5	O	DRV	Sensor drive pin
6	O	CFGDRV	Configuration circuit drive pin
7	A	SPEED	Speed setting analog input
8	I	PS2EN	Interface configuration pin: high = PS/2; low = Serial
9	IO	RESV	Reserved pin
10	O	TXD	Serial port transmit line
11	IO	CLK/RTS	PS/2 mouse clock or serial RTS line input
12	I	RXD	Serial port receive line
13	IO	DAT	PS/2 mouse data
14	IO	RESV	Reserved pin
15	A	YSIG	Sensor Y signal input
16	A	XSIG	Sensor X signal input
17	IO	nLBTN	Left button: active low with internal pull-up resistor
18	IO	nMBTN	Middle button: active low with internal pull-up resistor
19	IO	nRBTN	Right button: active low with internal pull-up resistor
20	P	VSS	Ground connection

LENGENG A = Analog, I = Input, O = Output, IO = Input/Output, P = Power

FUNCTION BLOCK DESCRIPTION

The SK7300 consists functionally of several major sections (see the block diagram on the previous page). These include the joystick and ErgoTrac sensor interface, the button interface, the oscillator circuit, the 8-bit timer, the power management, the power on reset, the EEPROM block, the serial mouse interface and the PS/2 mouse interface. All sections communicate with each other and operate concurrently.

Joystick and ErgoTrac Interface

The SK7300 provides power to either an analog joystick sensor or a Fujitsu ErgoTrac sensor, then the sensor outputs the XSIG and YSIG at the middle of the operation range. When the sensor is pressed by a user, the X output and Y output voltage will change following the pressure accordingly.

Button Interface

The SK7300 scans the button status along with the joystick/ErgoTrac sensor sampling.

Serial Mouse Interface

The SK7300 follows IBM/Microsoft standard serial mouse protocol to communicate with the host. The SK7300 transforms the digitized X, Y data into mouse report format and send it to the host. The SK7300 extends the standard serial mouse protocol to support bi-directional communication. The SK7300 command protocol is described in the serial communication section in this document.

PS/2 Mouse Interface

The SK7300 has internal pull-up resistors on data and clock lines. The SK7300 follows IBM standard PS/2 mouse protocol to communicate with the host. The SK7300 transforms the digitized X, Y data into mouse report format and send it to the host. The SK7300 command protocol is described in the PS/2 communication section in this document.

Power Management

The SK7300 has four power modes: operation mode and idle mode and power down mode. The SK7300 automatically switches the power modes to minimize the power consumption.

When there is any communication between the SK7300 and host, the SK7300 stays in operation mode. The SK7300 fully runs to get the best performance. The power consumption is about 550uA in this mode.

When there is not communication between the SK7300 and host for 10 seconds (programmable timing), the SK7300 switches to idle mode. In this mode, the SK7300 samples at rate of 1/10 of operation mode and then put itself into sleep for the idle time between samplings. The power consumption is about 70uA in this mode.

When the SK7300 receives power down command "E2, 44", the SK7300 enters power down mode. The only way to put the SK7300 out of from power down mode is a hardware reset. The power consumption is about 3uA in this mode.

Power On Reset Circuit

The SK7300 has build-in low voltage detector. The reset threshold is set to 2.2V.

Oscillator Circuit

The SK7300 has build-in oscillator circuit and no external crystal or resonator is needed. The SK7300 includes operation oscillator circuit and sleep oscillator circuit. The operation circuit provides the clock to all internal circuit. The sleep oscillator circuit provides clock when the SK7300 enters idle mode.

The external crystal or resonator can be placed If high precision communication is required,

8-bit Timer

The 8-bit timer provides the timing control for PS/2 communication, joystick/ErgoTrac sensor sampling.

SERIAL COMMUNICATION

Serial Hardware

The TXD, RXD and RTS lines are CMOS logic-level signals, suitable for direct connection to the pins of an UART. Interfacing via the RS-232 port requires an addition of an inverting driver and receiver.

Serial Port Setting

Communication through the serial port is bi-directional at a fixed speed of 1200 Baud, 8N1 protocol (8 data bits, 1 stop bit, no parity check). The protocol is compatible with the standard serial mouse 7N1 protocol (7 data bits, 1 stop bit, no parity check) since the highest bit is always set to 1 in the mouse data report. The standard mouse driver will treat the bit7 as stop bit and the stop bit as idle.

Reset

The host can reset the device at any time by setting the RTS line high. When RTS is set low after a delay of at least 100 ms, the SK7300 responds with two identification characters "M3" (0x4D, 0x33).

Serial Data Report Format

Data reports are four bytes long only if the middle button is depressed or changing state; otherwise, data reports are three bytes long. A data report is sent if motion is detected, or if buttons are pressed or released. X and Y motion is reported relative to the last report sent, in a two's complement form with 8-bit resolution. Therefore, motion values range from -128 to +127.

Byte 1	b0	X6	
	b1	X7: MSB of X data, sign bit	1 = negative
	b2	Y6	
	b3	Y7: MSB of Y data, sign bit	1 = negative
	b4	Right Button Status	1 = depressed
	b5	Left Button status	1 = depressed
	b6	Always 1	
	b7	Always 1	
Byte 2	b0	X0: LSB of X data	
	b1	X1	
	b2	X2	
	b3	X3	
	b4	X4	
	b5	X5	
	b6	Always 0	
	b7	Always 1	
Byte 3	b0	X0: LSB of Y data	
	b1	X1	
	b2	X2	
	b3	X3	
	b4	X4	
	b5	X5	
	b6	Always 0	
	b7	Always 1	
Byte 4	b0	Always=0	

b1	Always=0	
b2	Always=0	
b3	Always=0	
b4	Always=0	
b5	Middle Button status	1 = depressed
b6	Always=0	
b7	Always=1	

Serial Commands

The SK7300 serial mode uses the same command set as PS/2 mode. Please the following sections for detail information:

- PS/2 Error Handling
- Standard PS/2 Commands
- Extended PS/2 Commands (x"E2")
- Internal Register Table in Page 0
- Internal Register Table in Page 1
- Internal Register Table in Page 2F
- Internal Register Table in Page 30

Because the SK7300 may stay in idle mode to save power, a wakeup byte 0x00 need be sent to wakeup the IC from sleep mode; the response for this byte may be nothing or 0xFE; then the host can do further operation.

PS/2 COMMUNICATION

Power on Reset

At start-up or reset, the controller waits for about 650 milliseconds, and then sends x"AA" to the host, followed by a device ID of x"00". Then the IC sets itself to its default values, i.e. incremental stream mode with 1:1 scaling, and a sampling rate of 100 Hz. The IC then disables itself until a command x"F4" is received from the host.

PS/2 Data Report Format

The list shows the PS/2 report formats. In the data report, each of the two position values (X and Y) is expressed as a 9-bit two's complement integer with the most significant bit (the sign bit) stored separately in byte 1. If there is an overflow of the accumulator, the maximum positive or negative count is reported. The overflow bits are always set to 0.

Byte 1	b0	Left Button status	1 = depressed
	b1	Right Button Status	1 = depressed
	b2	Middle Button Status	1 = depressed
	b3	Reserved Always = 1	
	b4	X8: MSB of X data, sign bit	1 = negative
	b5	Y8: MSB of Y data, sign bit	1 = negative
	b6	Always 0	
	b7	Always 0	
Byte 2	b0	X0: LSB of X data	
	b1	X1	
	b2	X2	
	b3	X3	
	b4	X4	

	b5	X5
	b6	X6
	b7	X7
Byte 3	b0	Y0: LSB of Y data
	b1	Y1
	b2	Y2
	b3	Y3
	b4	Y4
	b5	Y5
	b6	Y6
	b7	Y7

PS/2 Error Handling

The controller sends an acknowledge x"FA" for every correct command or parameter received from the host.

The controller issues a Resend request x"FE" after the receipt of an invalid input. If a second invalid input is received after the Resend request, an error code x"FC" is transmitted to the host. Resend and error codes are sent for both commands and parameters. A response from the controller is transmitted within 25 milliseconds. If the controller is in stream mode, the host must disable the controller before issuing a command that requires a response from the controller.

Standard PS/2 Commands

The SK7300 implements all standard PS/2 mouse commands.

Reset (x"FF")

The system will issue a "Reset" command to initiate a software reset. The controller will set a sampling rate of 100 reports per second, resolution 02, stream mode, disabled, scaling off. The controller response will be x"FA" followed by the two byte packet x"AA 00".

Resend (x"FE")

The system can send this command when it detects an error in any transmission from the controller. The "Resend" command should be sent following a controller packet transmission and before the system enables the interface allowing the next controller output. On receipt of "Resend", the controller retransmits the previous packet, of one, two, or three bytes as the case may be. The ACK byte x"FA" is not counted in determining the size of a packet unless it was the only response, in which case the x"FA" will be resent. If a "Resend" command is received by the controller from the host immediately following a three byte data packet transmission from the controller to the host, the controller should resend the three byte data packet.

Set Default (x"F6")

Following receipt of this command, the controller will set a sampling rate of 100 reports per second, resolution 02, stream mode, disabled, scaling off. The Accumulators and button status bits will be cleared. The controller response will be x"FA".

Disable (x"F5")

When in stream mode, this command disables the initiation of transmissions by the controller. While disabled, the controller will respond to all other commands. If the controller is in stream mode, the host should disable it prior to sending any command that requires a response from the controller. When in remote mode, this command has no effect, but will be reflected in the status byte as described in "Status Request" (x"E9"), and will be effective on return to Stream mode. The controller response will be x"FA".

Enable (x"F4")

This command allows the controller to begin transmissions to the host if it is in stream mode at the current sampling rate. When in remote mode, this command has no effect, but will be stored for later use when in stream mode and will be reflected in the status byte as described in "Status Request" (x"E9"). The controller response will be x"FA".

Set Sampling Rate (x"F3,XX")

This command is effective only stream mode. When in remote mode, this command has no effect, but will be stored for later use when in stream mode and in the status byte as described in "Status Request" (x"E9"). A rate of 100 reports per second is the reset default. This is a two byte command where the second byte indicates the sampling rate. The valid values are x"0A", x"14", x"28", x"3C", x"50", x"64", x"C8". The controller response will be x"FA".

The actual sampling rate of SK7300 is always 100 per second. The sensor measurement rate is 100 per second, to maintain proper performance.

Read Device Type (x"F2")

The controller will always respond with an x"00" to this command, corresponding to a "mouse-like" device.

Set Remote Mode (x"F0")

This command resets stream mode. In remote mode, data values are reported only in response to a "Read Data" command. The controller response will be x"FA".

Set Wrap Mode (x"EE")

This command places the controller in wrap mode. After transmission of the ACK byte, all data bytes except x"FF" or x"EC" that are sent to the controller will be immediately returned by the controller (without ACK). The controller will remain in the wrap mode until it receives a "Reset Wrap Mode" (x"EC") or "Reset" (x"FF") command.

Reset Wrap Mode (x"EC")

This command resets wrap mode. The controller will return to the previous mode of operation after receiving this command. However, if "Set Wrap Mode" is entered after the controller has been operating in "Stream Mode", the controller will reenter "Stream Mode" disabled after receipt of a "Reset Wrap Mode" command. If the controller is not in the wrap mode when this command is received, the command will be acknowledged, but its state will not be affected. The controller response will be x"FA".

Read Data (x"EB")

This command requests that the controller transmit all the data defined in the data packet format as described in "Data Report". This command may be executed in either remote or stream mode. The data will be transmitted even if there has been no activity since the last report. The integer portion of the count accumulators will be cleared. The controller response will be x"FA" followed by a three byte packet with the data format as specified in "Data Report".

Set Stream Mode (x"EA")

This command sets the controller in stream mode. This command resets remote mode. If enabled, data will be transmitted to the system in the format described in "Data Report" when there is any activity detected. The controller response will be x"FA".

Status Request (x"E9")

When this command is issued by the host, the controller will respond with a 3-byte status report as follows:

Byte 1	b0	Right Button Status	1 = depressed
	b1	Middle Button Status	1 = depressed
	b2	Left Button status	1 = depressed
	b3	Reserved Always = 0	
	b4	Scaling	0 = 1:1; 1 = 2:1

b5	Enable/Disable	0 = Disable; 1 = Enable
b6	Stream/Remote mode	0 = Stream; 1 = Remote
b7	Always 0	
Byte 2	Current resolution	
Byte 3	Current sampling rate	

Set Resolution (x"E8,XX")

This command has no effect for the controller. The default value is x"02". The controller response will be x"FA". Valid values are x"00", x"01", x"02", x"03".

Set Scaling 2:1 (x"E7")

This command has no effect in the controller. The controller response will be x"FA".

Reset Scaling 1:1 (x"E6")

This command has no effect in the controller. The controller response will be x"FA".

Read Secondary ID (x"E1")

This command will read the secondary device ID of the pointing device (2 bytes). The least significant byte is sent first. The controller response will be x"00, 73".

Extended PS/2 Commands (x"E2")

The SK7300 controller extends PS/2 mouse commands to support joystick/ErgoTrac specific feature control using command x"E2".

Power Down (x"E2, 44")

Power down the controller permanently. The only recovery from this command is a hardware reset.

Power On Reset (x"E2, 7F")

Following the acknowledgment to this command, the controller will proceed to execute instructions from its power on or hard reset vector. All parameters will be reset to their power on default values, and a POST completion response of x"AA 00" will be transmitted upon completion.

Read ROM Version (x"E2, 46")

The command is to read ROM version. The controller response is two bytes. The byte 1 is version# and byte 2 is revision#.

Force Calibration (x"E2, 51")

This command will perform the whole pointing stick calibration cycle after the acknowledge byte is sent. The cycle will take approximately 50 milliseconds to complete. The controller response will be x"FA".

The following commands are used to manipulate the SK7300 internal registers. Refer to the SK7300 internal register table following this section.

Quick Read Register (x"E2, XX")

This command is to read the contents of register "XX". The second byte is from x"00" to x"3F".

Read Register (x"E2, 80, XX")

This command is to read the contents of register "XX". The command is identical to the Quick Read Register command x"E2 XX" for arguments < x"3F".

Write Register (x"E2, 81, XX, YY")

This command is to write byte "YY" to register "XX".

Read Register Block (x"E2, 82, XX")

This command is to read the contents of register “XX” to “XX + 5”. The response has 6 bytes and the content in low location is returned first.

Get Register Page Number (x"E2, 83")

This command is to return current register page number. The default page number is 0. The page number will be reset to 0 when the SK7300 receives commands Reset (x"FF") and Set Default (x"F6").

Set Register Page Number (x"E2, 84, XX")

This command is to set current register page to page “XX”.

Toggle Register Bits (x"E2, 47, XX, YY")

This command is to toggle specific register bits. Byte three “XX” is the address of the register, in the range of x"00"-x"FF". Byte four is logically exclusive ORed with the current register value.

Internal Register Table in Page 0

This page contains registers in RAM.

Register Index	Bit Position	Description	Default
0x00-0xFF		Internal control registers	

Internal Register Table in Page 1

This page contains registers in RAM.

Register Index	Bit Position	Description	Default
0x00-0xFF		Internal control registers	

Internal Register Table in Page 2F

This page stores the device information in flash.

Register Index	Bit Position	Description	Default
0x00-x01		Part number	0073
0x02		Version number	
0x03		Revision number	

Internal Register Table in Page 30

This page is configuration page. All registers are stored in on-chip EEPROM memory.

Register Index	Bit Position	Description	Default
0x00 – 0x7F		Internal configuration registers. After power up, these registers are loaded into RAM.	
0x80 – 0xBF		EEPROM area for the host	0xFF

ELECTRONICS SPECIFICATION

Absolute Maximum Ratings

Symbol	Description	Min	Typ	Max	Units	Notes
TSTG	Storage Temperature	-65	-	+150	°C	
VDD	Supply Voltage on Relative to VSS	-0.5	-	+6.5	V	
VIO	DC Input Voltage	VSS-0.5	-	VDD+0.3	V	
VIOZ	DC Voltage Applied to Tri-State	VSS-0.5	-	VDD+0.3	V	
IMIO	Maximum Current into any Port Pin	-25	-	+25	mA	
ESD	Electro Static Discharge Voltage	2000	-	-	V	Human Body Model ESD

Operating Temperature

Symbol	Description	Min	Typ	Max	Units	Notes
TOP	Operating Temperature	-40	-	+85	°C	

DC Electrical Characteristics

Symbol	Description	Min	Typ	Max	Units	Notes
VDD	Supply Voltage	2.2	-	5.5	V	
IDD1	Supply Current when IC is in operation mode for PS/2 interface		550		µA	VDD = 5.0V Note1
			360		µA	VDD = 3.3V Note1
IIDLE1	Supply Current when IC is in idle mode for PS/2 interface		70		µA	VDD = 5.0V Note1
			50		µA	VDD = 3.3V Note1
IDD2	Supply Current when IC is in operation mode for serial interface		650		µA	VDD = 5.0V Note1
			420		µA	VDD = 3.3V Note1
IIDLE2	Supply Current when IC is in idle mode for serial interface		80		µA	VDD = 5.0V Note1
			50		µA	VDD = 3.3V Note1
ISD	Supply Current when IC is in power down mode		3		µA	
RPU	Pull-up Resistor	12.5	20	100	kΩ	VDD = 5.0V
VOH	High Output Level	VDD-0.7	-	-	V	VDD = 5.0V, IOH = -3mA
VOL	Low Output Level	-	-	0.6	V	VDD = 5.0V, IOL = 8.5mA
VIL	Input Low Level	-	-	0.2VDD	V	
VIH	Input High Level	0.8VDD	-	-	V	
VIL	Input Leakage Current (Absolute Value)	-	0.1	-	µA	
LVD	Low voltage Detection	2.0	-	2.2	V	

Note1: The measurement is done with 10k analog joystick sensor; For Fujitsu FID-828 ErgoTrac Hall-effect sensor, add 400µA to operation mode; 40µA to idle mode under VDD = 5.0V.

Analog Joystick Sensor Characteristics

Symbol	Description	Min	Typ	Max	Units	Notes
RS	Joystick Sensor Resistor Value	1	-	100	kΩ	
R1/R2	Matching Ration in X and Y direction	TBD	-	TBD	%	
TRS	Tolerance of Each Sensor Resistor	-	-	TBD	%	

PACKAGING INFORMATION

SK7300-PV Drawing

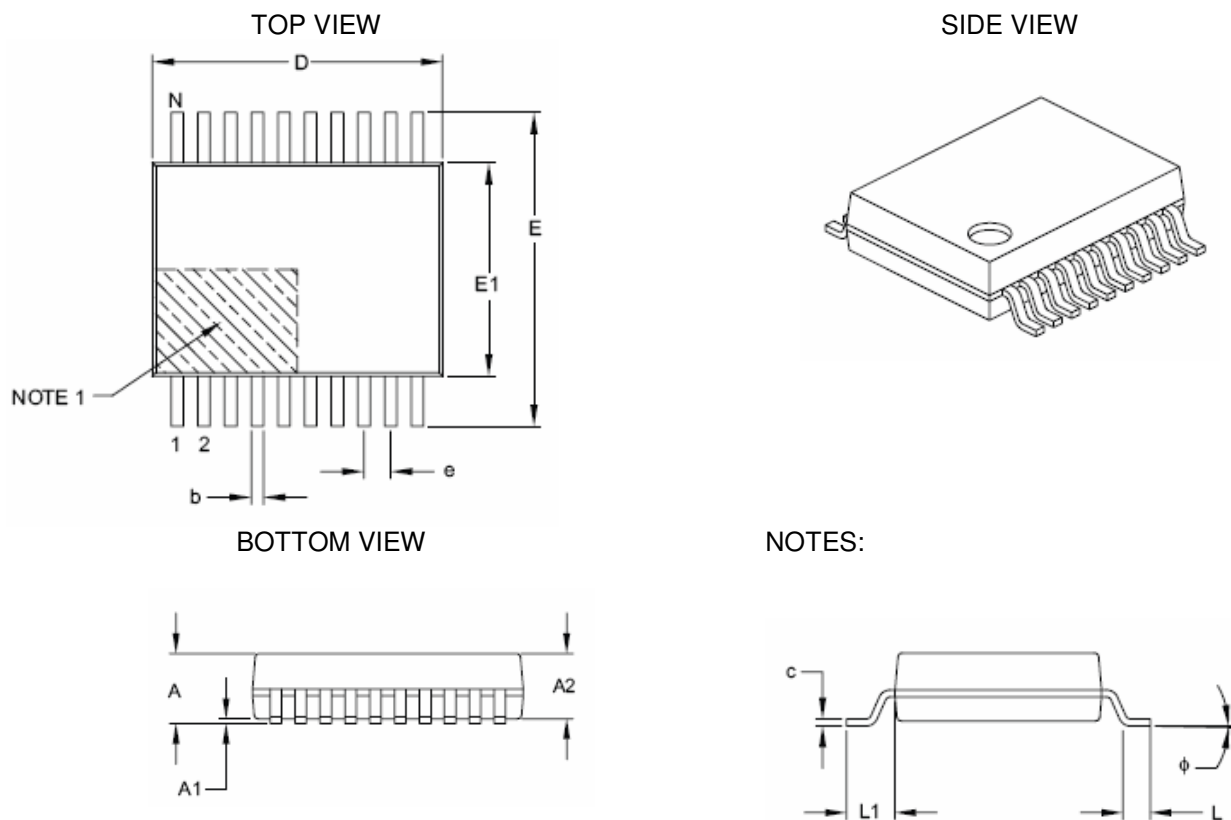

Dimension Limits	Units	MILLIMETERS		
		MIN	NOM	MAX
Number of Pins	N	20		
Pitch	e	0.65 BSC		
Overall Height	A	–	–	2.00
Molded Package Thickness	A2	1.65	1.75	1.85
Standoff	A1	0.05	–	–
Overall Width	E	7.40	7.80	8.20
Molded Package Width	E1	5.00	5.30	5.60
Overall Length	D	6.90	7.20	7.50
Foot Length	L	0.55	0.75	0.95
Footprint	L1	1.25 REF		
Lead Thickness	c	0.09	–	0.25
Foot Angle	φ	0°	4°	8°
Lead Width	b	0.22	–	0.38

SK7300-PV 20-Lead (7.8x7.2mm 2.0 MAX) SSOP

Note1: Pin 1 visual index feature may vary, but must be located within hatched area.

SALE AND SERVICE INFORMATION

To obtain information about Sprintek Corporation or joystick/ErgoTrac mouse encoder controller sales and technical support, reference the following information.

Sprintek Corporation

4528 La Tuna Ct.

Camarillo, CA 93012, USA

Phone: 805.405.8787

Web Site: <http://www.sprintek.com>

REVISION HISTORY

Revision	Issue Date	Description
0.10	4/27/2009	Initial Release