

## SK5102 FlexMatrix Keyboard Controller

Sprintek Corporation

User-Programmable USB Keyboard and KeyMouse Combo Encoder with an External PS/2 Port and AB Rotary Encoder Support

### FEATURES

- USB 2.0 full speed
- User-Programmable keyboard matrix
- 4 sets of 8 x 20 keyboard matrix for Numlock(or RFN) and FN cases
- Up to 255 Custom/Macro keys: generate “LCTRL+LALT+DEL”, “000” and “Diet Coke”
- N-Key Rollover Support
- Built-in KeyMouse
- AB rotary encoder mapped keys
- Support PS/2 command pass-through via USB port
- Key-controlled and USB-controlled 8 general purpose output(GPO), 1 state control output(SCO), 1 backlight PWM, 1 Alert LED control, Blackout control
- Support three FN control modes: Level, Toggle and Sticky.
- Support two delay keys
- Supports USB selective suspend and remote wakeup
- Built-in oscillator and digital circuit. No external crystal is needed
- Windows® application to design keyboard matrix
- Low profile QFN 56 pin package: 8x8mm 1.0 Max (LxWxH)
- Low power consumption. 230uA (USB suspend) and 18 mA (USB operation)
- 4.57 to 5.25V operating voltage
- Commercial temperature range:0°C to +70°C
- Custom versions available in small and large quantities

### APPLICATION

- Netbook PCs
- Notebook PCs
- Industrial Keyboard
- Point-of-sale (POS) terminals
- Portable devices

### ORDEING INFORMATION

**SK5102-LT** Saw QFN 56-pin, 0.5mm pitch, (8x8mm 1.0 MAX), Pb-Free, RoHS

### DESCRIPTION

The SK5102 is a USB keyboard and KeyMouse combo encoder with a user-programmable keyboard matrix. The IC can be programmed to any keyboard with four matrix tables for FN and NUMLOCK(or RFN) cases, so the IC is the best choice for custom keyboard solution but with an off-the-shelf IC.

The SK5102 scans and encodes an 8-row by 20-column matrix. The key press events are translated to keyboard and mouse report. The encoder gets matrix information from on-chip flash matrix table. Sprintek provides Windows® application FlexMatrix Editor and Programmer software to edit, download and upload the matrix table.

The SK5102 scans AB rotary encoder inputs then map the rotation events to two key locations in the key matrix.

The SK5102 provides an external PS/2 port that supports hot plug and hot swap of PS/2 mouse including wheel mouse, and keyboard devices.

### PIN ASSIGNMENTS

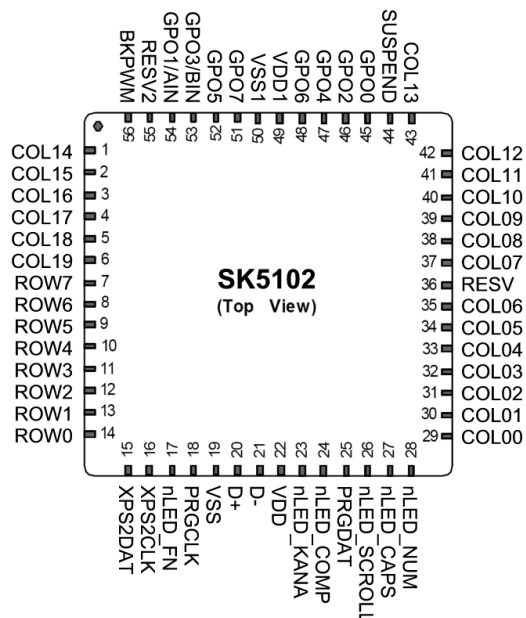

**FUNCTION BLOCK DIAGRAM**

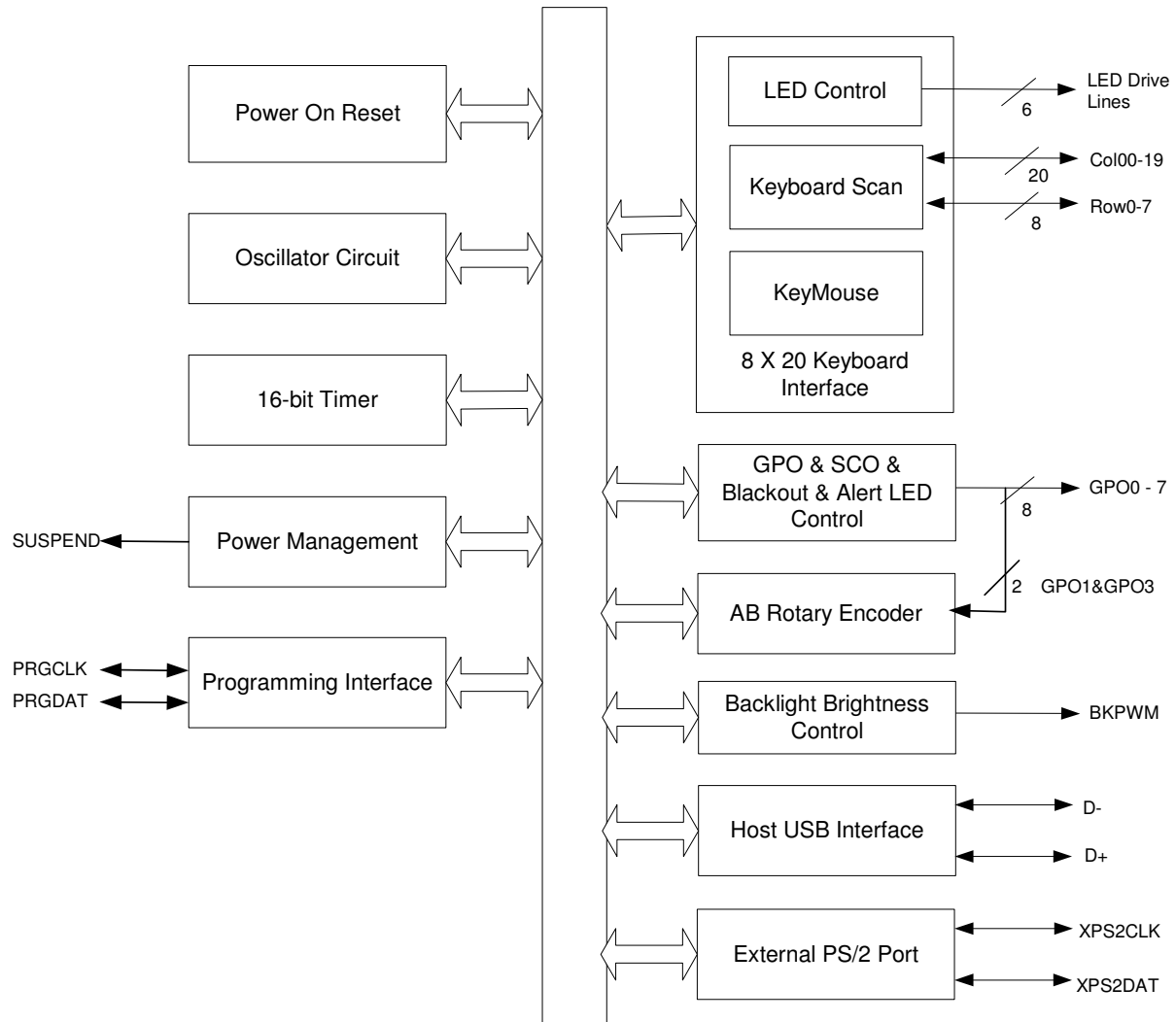

## PIN DEFINITION

Pin No	Type	Name	Description
1 – 6	IO	C14 – C19	Column lines 14 to 19 for scan matrix
7 – 14	IO	R7 – R0	Row lines 0 to 7 for scan matrix with internal pull-down resistor
15	IO	XPS2DAT	External PS/2 port data line with internal pull-up resistor
16	IO	XPS2CLK	External PS/2 port clock line with internal pull-up resistor
17	O	nLED_FN	FN LED: direct drive
18	IO	PRGCLK	Programming interface clock line
19	P	VSS	Ground connection
20	IO	D+	USB D+ line
21	IO	D-	USB D+-line
22	P	VDD	Power supply
23	O	nLED_KANA	KANA LED: direct drive
24	O	nLED_COMP	Composer LED: direct drive
25	IO	PRGDAT	Programming interface data line
26	O	nLED_SCRO LL	Scroll lock LED: direct drive
27	O	nLED_CAPS	Caps lock LED: direct drive
28	O	nLED_NUM	Num lock LED: direct drive
29 – 35	IO	C00 – C06	Column lines 00 to 06 for scan matrix
36	I	RESV	This pin is reserved.
37 – 43	IO	C07 – C13	Column lines 07 to 13 for scan matrix
44	O	SUSPEND	Valid in USB mode. High = keyboard is in suspend mode; low = normal running mode.
45 - 48	O	GPO0,2,4,6	GPO pins
49	P	VDD1	Power supply
50	P	VSS1	Ground connection
51 – 52	O	GPO7,5,3,1	GPO pins.
53	IO	GPO3/BIN	GPO3 or AB rotary B input
54	IO	GPO1/AIN	GPO1 or AB rotary A input
55	I	RESV2	This pin is reserved.
56	O	BKPWM	Backlight brightness control: PWM output
CP	P	CP	The center pad on the QFN package should be connected to ground (VSS) for best mechanical, thermal, and electrical performance. If not connected to ground, it should be electrically floated and not connected to any other signal.

LENGENG I = Input, O = Output, IO = Input/Output, P = Power

## FUNCTION BLOCK DESCRIPTION

The SK5102 consists functionally of several major sections (see the block diagram on the previous page). These include the keyboard and KeyMouse interface, the AB rotary encoder interface, the oscillator circuit, the 16-bit timer, programming interface, external PS/2 port, backlight control circuit, GPO&SCO control, flash data block and the USB interface. All sections communicate with each other and operate concurrently.

### Keyboard and KeyMouse Interface

The SK5102 scans a keyboard organized as an 8 row by 20 column matrix for a maximum of 160 keys. Smaller size matrixes can be accommodated by leaving unused pins open. The IC provides internal pull-ups for the row input pins. When active, the encoder selects each column line (C0-C19); for each column selected, it reads the row data lines (R0-R7). A key closure is detected as a zero in the corresponding position of the matrix.

Each key found pressed is debounced for a period of 24 ms. Once the key is verified, the corresponding key code(s) are loaded into the transmit buffer.

In any scanned contact switch matrix, whenever three keys defining a rectangle on the switch matrix are pressed at the same time, a fourth key positioned on the fourth corner of the rectangle is sensed as being pressed. This is known as the “ghost” or “phantom” key problem.

Although the problem cannot be totally eliminated without using external hardware, there are methods to neutralize its negative effects for most practical applications. Keys that are intended to be used in combinations should be placed in the same row or column of the matrix, whenever possible. Shift keys (Shift, Alt, Ctrl, Window) should not reside in the same row (or column) as any other keys. The SK5102 has built-in mechanisms to detect and reject “ghost” keys.

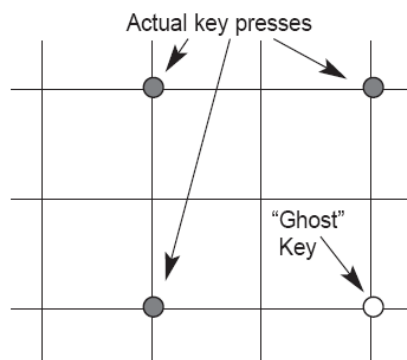

When an external hardware (normally adding diode to each key switch) is used, the ghost key mechanism can be disabled via FlexMatrix Editor. This feature enables N-key rollover designs.

The SK5102 provides 6 high current sink pins to drive LEDs directly. The LEDs are CapsLock, Numlock, Scrolllock, Composite, Kana and FN.

The SK5102 simulate Windows KeyMouse function without any additional software support. It supports 8 direction movement, Z scroll functions, mouse button functions (left, middle, right, backwards, forwards). All these features can be mapped to any location in the key matrix.

### AB Rotary Encoder Interface

The IC interfaces to an AB rotary encoder to get the rotation events via AIN and BIN. The clockwise and counterclockwise rotation events can be mapped to any key location in the key matrix. For example, it is mapped to volume up key and volume down key at location (C19, R0) and (C19, R1) at default key matrix.

The IC supports three kinds of AB rotary encoders: no detent, 1 detent/pulse, 2 detents/pulse. The type can be configured in FlexMatrix Editor.

The AB rotary interface can be disabled by downloading new matrix data. Disabling AB rotary function reduces 150uA power consumption for suspend mode.

## USB Interface

The SK5102 interfaces to PC via a USB port. The IC follows USB.org's *Universal Serial Bus Specification 2.0* and *Device Class Definition for HID 1.11* as a full speed HID composite device. The SK5102/SK5103 has three function endpoints for bootable keyboard, bootable mouse, and consumer and system keys.

## Power Management

The SK5102 supports selective suspend and remote wake up to get maximum power saving. AB rotary encoder feature adds only 50uA to the total power consumption.

## Power On Reset Circuit

The SK5102 has built-in low voltage detector.

## Oscillator Circuit

The SK5102 has build-in oscillator circuit and no external crystal or resonator is needed. The oscillator provides high frequency and 32k low frequency clocks to other blocks.

## 16-bit Timer

The 16-bit timer provides the timing control for USB or PS/2 communication, keyboard scan and sleep timer wakeup.

## Programming Interface

The programming interface is reserved for Sprintek to programming new firmware. **PRGCLK and PRGDAT pins are recommended to be connected to a 5 pin header J4 in the schematic.** The header needn't be populated in the final assembly. Two test points are preferred if 5 pin header is not allowed due to space reason.

## Backlight Control Circuit

The 8-bit PWM output controls the brightness of backlight circuit. The PWM clock is sourced from 32k clock, the parameters such as period, positive width are programmable.

8-bit SCO can be used for a low cost backlight solution too.

## GPO, SCO, Blackout and Alert LED Control

The SK5102 provides 8 general purpose output (GPO) pins that can be associated to any keys. The GPO pins are operated independently. The IC also provides state control output (SCO) logic that can be associated to one key. The SCO controls several GPO together in a predefined table. Blackout is a GPO configured in toggle mode. Alert LED control pin shares pinout with GPO7. All GPO ports can be configured to resistive pullup, resistive pulldown, strong drive and high-Z four modes.

The GPO and SCO states can be set and read via USB command. The Sprintek command protocol is available with NDA signed.

### **External PS/2 Port**

The SK5102 provides an external PS/2 port that supports hot plug and hot swap of PS/2 mouse including wheel mouse, and keyboard devices.

The SK5102 supports USB command to relay PS/2 command from the USB port to the external PS/2 port. This enables a customized mouse driver to setup external PS/2 mouse such as touchpad.

### **Flash Data Block**

The SK5102 provides an on-chip flash data block to store keyboard matrix, KeyMouse speed profile, AB rotary encoder key mapping settings, GPO and SCO control parameters, backlight control parameters, SKey-scan code mapping table and etc. The flash data block can be edited via FlexMatrix Editor program, uploaded and downloaded via FlexMatrix Programmer program.

## KEYBOARD MATRIX DESIGN

### Four Keyboard Matrix

The SK5102 supports four 8X20 keyboard matrixes for the following cases: Fn off and Numlock(or RFn) off, Fn off and Numlock(or RFn) on, Fn on and Numlock(or RFn) off, and Fn on and Numlock(or RFn) on. The keyboard matrix is stored in on-chip flash memory. The matrix is programmable by FlexMatrix Editor and Programmer software.

### Design Keyboard Matrix

Please refer to Microsoft Windows Platform Design Notes "Keyboard Scan Code Specification" to get more information.

### Create Keyboard Matrix and Fn Mode

The FlexMatrix Editor program enables the user to create keyboard matrix including macro key definition and function key definition, then save them in binary format.

The Editor program allows the user to assign a logical key to any position in the 8 x 20 matrix for each of four situations:

Matrix0 – Num Lock(or RFn) off and Fn off

Matrix1 – Num Lock(or RFn) on and Fn off

Matrix2 – Num Lock(or RFn) off and Fn on

Matrix3 – Num Lock(or RFn) on and Fn on

Fn state is controlled by LFn (function) key in three methods: Level, Toggle and Sticky. The setting is can be changed via FlexMatrix Programmer.

Fn Level mode: when Fn key is pressed, Fn mode is on; when Fn key is released, Fn mode is off.

Fn Toggle mode: when Fn key is pressed, Fn mode is inverted; Releasing Fn key does nothing.

Fn Sticky mode: when Fn is pressed once, Fn is in sticky state; when Fn is pressed twice, Fn is on state; when Fn is pressed for three times, Fn is off state. When Fn is in sticky state, any other key press will change Fn mode to off state.

The Editor program also allows the user to create up to 255 macro keys, which can then be assigned to positions in the matrix.

Once a matrix has been created, it is saved in a binary file. The file can be downloaded to the SK5102 flash data block via FlexMatrix Programmer software.

For detailed information and instructions for the FlexMatrix Editor program, see the help file provided with the program.

The Editor program can be downloaded from the SK5102 page on the Sprintek web site

<http://www.sprintek.com/>

Here is the screen snapshot of FlexMatrix Editor software.

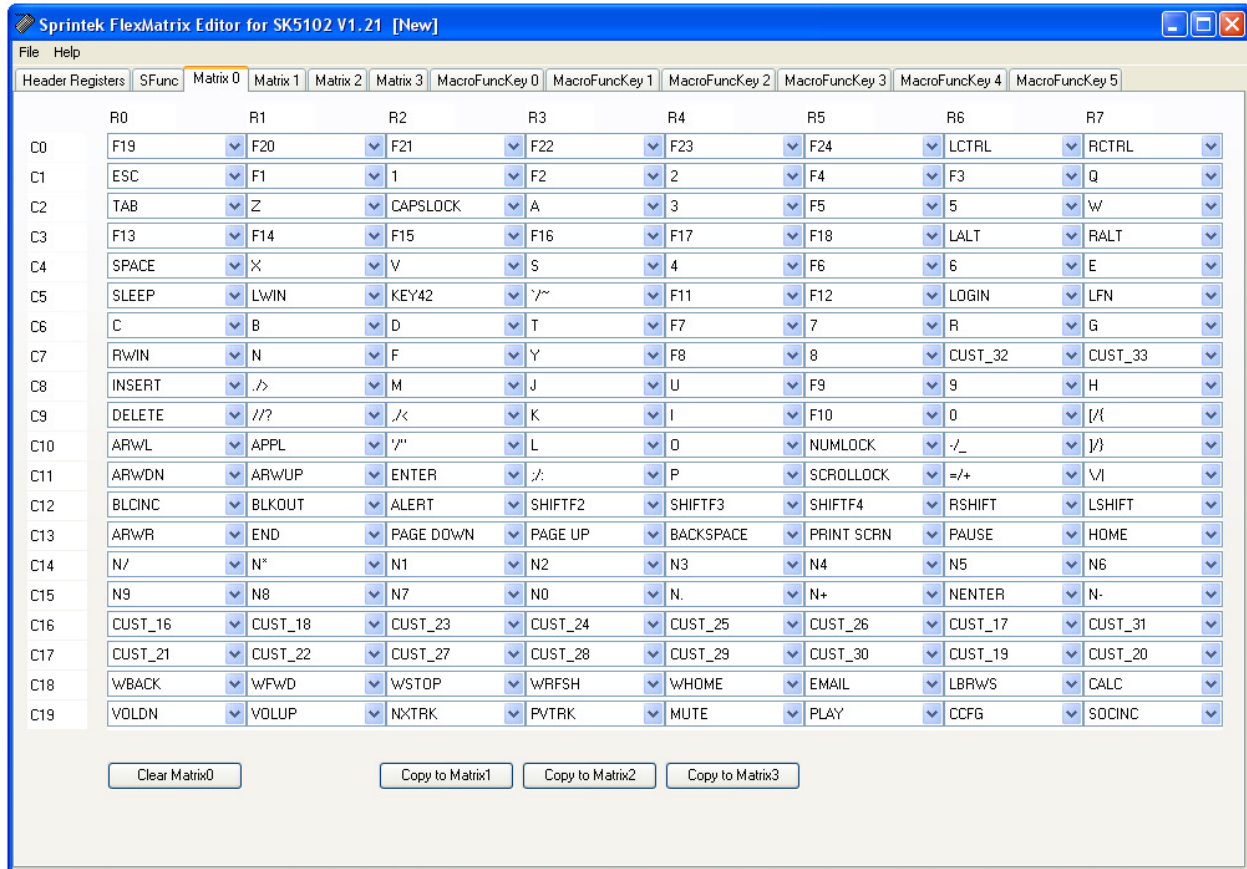

## Download Keyboard Matrix

The FlexMatrix Programmer program enables the user to download matrix binary file to the SK5102, upload matrix data from the SK5102's flash data block to a binary file.

The Programmer program can be downloaded from the SK5102 page on the Sprintek web site

<http://www.sprintek.com/>

Here is the screen snapshot of FlexMatrix Programmer software.



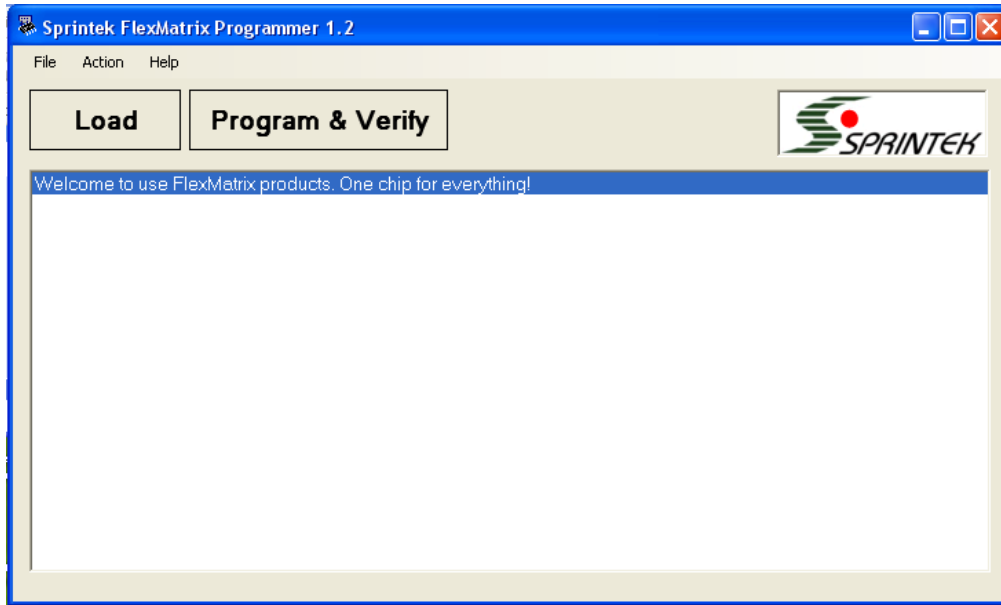

### Test Keyboard Matrix

Sprintek offers a keyboard test tool to verify your keyboard design. The FlexMatrix Tester software can be downloaded from the SK5102 page on the Sprintek web site <http://www.sprintek.com/>

Here is the screen snapshot of FlexMatrix Tester software.

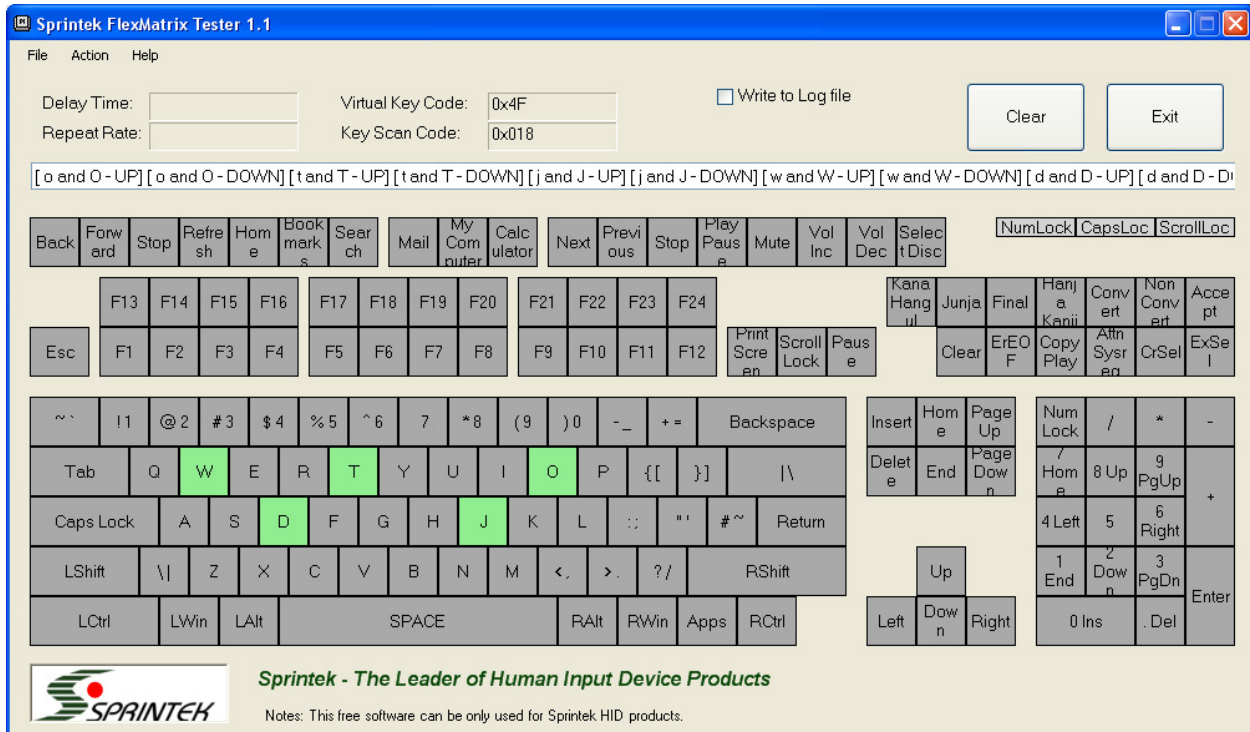

## DEFAULT KEYBOARD MATRIX

The following table shows the default keyboard matrix on chip.

Col	Row	Fn Off Numlock Off	Fn Off Numlock On	Fn On Numlock Off	Fn On Numlock On
0	0	F19	F19		
0	1	F20	F20		
0	2	F21	F21		
0	3	F22	F22		
0	4	F23	F23		
0	5	F24	F24		
0	6	LCTRL	LCTRL		
0	7	RCTRL	RCTRL		
1	0	ESC	ESC		
1	1	F1	F1		
1	2	1	1		
1	3	F2	F2		
1	4	2	2		
1	5	F4	F4		
1	6	F3	F3		
1	7	Q	Q		
2	0	TAB	TAB		
2	1	Z	Z		
2	2	CAPSLOCK	CAPSLOCK		
2	3	A	A		
2	4	3	3		
2	5	F5	F5		
2	6	5	5		
2	7	W	W		
3	0	F13	F13		
3	1	F14	F14		
3	2	F15	F15		
3	3	F16	F16		
3	4	F17	F17		
3	5	F18	F18		
3	6	LALT	LALT		
3	7	RALT	RALT		
4	0	SAPCE	SAPCE		
4	1	X	X		
4	2	V	V		
4	3	S	S		
4	4	4	4		
4	5	F6	F6		
4	6	6	6		
4	7	E	E		
5	0	SLEEP	SLEEP	SLEEP	SLEEP
5	1	LWIN	LWIN		
5	2	KEY45	KEY45		
5	3	~/	~/		
5	4	F11	F11		
5	5	F12	F12		
5	6	LOGIN	LOGIN	LOGIN	LOGIN
5	7	LFN	LFN	LFN	LFN
6	0	C	C		
6	1	B	B		
6	2	D	D		

6	3	T	T		
6	4	F7	F7		
6	5	7	7		
6	6	R	R		
6	7	G	G		
7	0	RWIN	RWIN		
7	1	N	N		
7	2	F	F		
7	3	Y	Y		
7	4	F8	F8		
7	5	8	8		
7	6	CUST_32	CUST_32		
7	7	CUST_33	CUST_33		
8	0	INSERT	INSERT		
8	1	./>	./>		
8	2	M	M		
8	3	J	J		
8	4	U	U		
8	5	F9	F9		
8	6	9	9		
8	7	H	H		
9	0	DELETE	DELETE		
9	1	//?	//?		
9	2	./<	./<		
9	3	K	K		
9	4	I	I		
9	5	F10	F10		
9	6	0	0		
9	7	[/{	[/{		
10	0	ARWL	ARWL		
10	1	APPS	APPS		
10	2	'/'	'/'		
10	3	L	L		
10	4	O	O		
10	5	NUMLOCK	NUMLOCK		
10	6	-/_	-/_		
10	7	]}	]}		
11	0	ARWDN	ARWDN		
11	1	ARWUP	ARWUP		
11	2	ENTER	ENTER		
11	3	:/	:/		
11	4	P	P		
11	5	SCRLOCK	SCRLOCK		
11	6	=/+	=/+		
11	7	√	√		
12	0	BLCINC	BLCINC	BLCINC	BLCINC
12	1	BLKOUT	BLKOUT	BLKOUT	BLKOUT
12	2	ALERT	ALERT	ALERT	ALERT
12	3	SHIFTF2	SHIFTF2	SHIFTF2	SHIFTF2
12	4	SHIFTF3	SHIFTF3	SHIFTF3	SHIFTF3
12	5	KEY42	KEY42	KEY42	KEY42
12	6	RSHIFT	RSHIFT		
12	7	LSHIFT	LSHIFT		
13	0	ARWR	ARWR		
13	1	END	END		
13	2	PAGEDN	PAGEDN		
13	3	PAGEUP	PAGEUP		
13	4	BKSPACE	BKSPACE		
13	5	PRNTSCR	PRNTSCR		

13	6	PAUSE	PAUSE		
13	7	HOME	HOME		
14	0	N/	N/		
14	1	N*	N*		
14	2	N1	N1		
14	3	N2	N2		
14	4	N3	N3		
14	5	N4	N4		
14	6	N5	N5		
14	7	N6	N6		
15	0	N9	N9		
15	1	N8	N8		
15	2	N7	N7		
15	3	N0	N0		
15	4	N.	N.		
15	5	N+	N+		
15	6	NENTER	NENTER		
15	7	N-	N-		
16	0	CUST_16	CUST_16	CUST_16	CUST_16
16	1	CUST_18	CUST_18	CUST_18	CUST_18
16	2	CUST_23	CUST_23	CUST_23	CUST_23
16	3	CUST_24	CUST_24	CUST_24	CUST_24
16	4	CUST_25	CUST_25	CUST_25	CUST_25
16	5	CUST_26	CUST_26	CUST_26	CUST_26
16	6	CUST_17	CUST_17	CUST_17	CUST_17
16	7	CUST_31	CUST_31	CUST_31	CUST_31
17	0	CUST_21	CUST_21	CUST_21	CUST_21
17	1	CUST_22	CUST_22	CUST_22	CUST_22
17	2	CUST_27	CUST_27	CUST_27	CUST_27
17	3	CUST_28	CUST_28	CUST_28	CUST_28
17	4	CUST_29	CUST_29	CUST_29	CUST_29
17	5	CUST_30	CUST_30	CUST_30	CUST_30
17	6	CUST_19	CUST_19	CUST_19	CUST_19
17	7	CUST_20	CUST_20	CUST_20	CUST_20
18	0	WBACK	WBACK	WBACK	WBACK
18	1	WFWD	WFWD	WFWD	WFWD
18	2	WSTOP	WSTOP	WSTOP	WSTOP
18	3	WRFSH	WRFSH	WRFSH	WRFSH
18	4	WHOME	WHOME	WHOME	WHOME
18	5	MAIL	MAIL	MAIL	MAIL
18	6	LBRWS	LBRWS	LBRWS	LBRWS
18	7	CALC	CALC	CALC	CALC
19	0	VOLUP	VOLUP	VOLUP	VOLUP
19	1	VOLDN	VOLDN	VOLDN	VOLDN
19	2	NXTRK	NXTRK	NXTRK	NXTRK
19	3	PVTRK	PVTRK	PVTRK	PVTRK
19	4	MUTE	MUTE	MUTE	MUTE
19	5	PLAY	PLAY	PLAY	PLAY
19	6	CCFG	CCFG	CCFG	CCFG
19	7	SCOCINC	SCOCINC	SCOCINC	SCOCINC

CUST\_16 to 31 are KeyMouse functions. Check scan code table for detail.

CUST\_32: Key "00"

CUST\_33: Key "000"

## SKEY AND SCAN CODE TABLE

The SK5102 supports 255 keys excluding the null key (0). The following table shows the default assignment of these keys. Any key can be assigned to any scan code via FlexMatrix Editor and Programmer.

### Table Notes

**SKEY** is the Sprintek key number.

**Program code** is the code entered by the user in the Editor program to identify the key

**AT-101** is the key reference number on the standard AT-101 keyboard layout, shown in the diagram below

**USB page** is the Universal Serial Bus (USB) Human Interface Device (HID) usage page for the key. Most keys are on the keyboard page, page 0x07. For information about USB codes, see the USB HID specifications, published by the USB-IF (<http://www.usb.org/>).

**USB usage** is the USB HID usage ID for the key on the specified USB HID page.

**PS/2 codes** are the make (key press) and break (key release) codes for PS/2 scan sets 1, 2, and 3; U/A means unassigned. Note that some keys, by default, do not generate break codes, even if the break codes are shown in this table.

### Enhanced AT-101 Keyboard Physical Layout

The following figure shows the standard AT-101 keyboard with Windows keys. The numbers on keys are the position number.

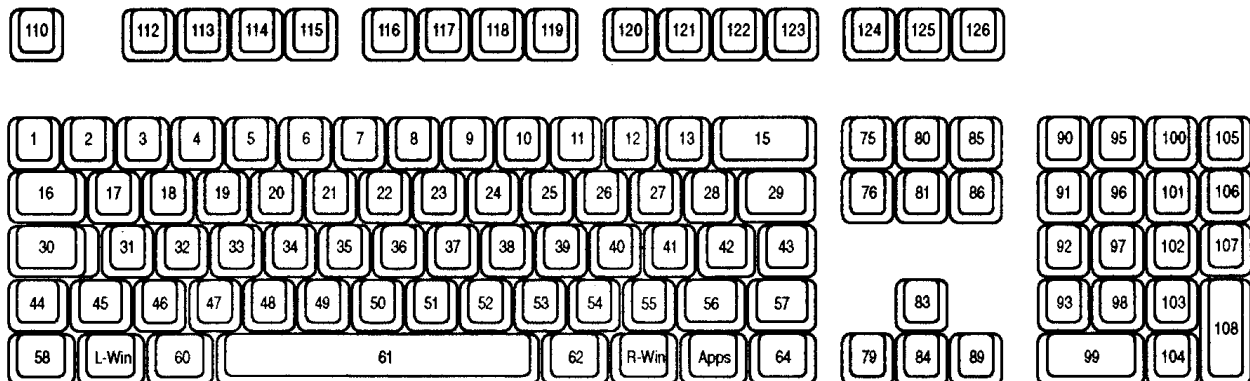

## SKey and Scan Code Table

SKEY (Dec)	Program Code	Description	AT- 101 (Dec)	USB Page (Hex)	USB Usage (Hex)	Set 1 Make (Hex)	Set 1 Break (Hex)	Set 2 Make (Hex)	Set 2 Break (Hex)	Set 3 Make (Hex)	Set 3 Break (Hex)
0	No Key	No Event	N/A	07	00	None	None	None	None	None	None
1	ROLLOVER	Keyboard ErrorRollOver	N/A	07	01	FF	None	00	None	None	None
2	POSTFAIL	Keyboard POSTFail	N/A	07	02	FC	None	FC	None	None	None
3	UNDEFINED	Keyboard ErrorUndefined	N/A	07	03	U/A	U/A	U/A	U/A	U/A	U/A
4	A	Keyboard a and A	31	07	04	1E	9E	1C	F0 1C	1C	F0 1C
5	B	Keyboard b and B	50	07	05	30	B0	32	F0 32	32	F0 32
6	C	Keyboard c and C	48	07	06	2E	AE	21	F0 21	21	F0 21
7	D	Keyboard d and D	33	07	07	20	A0	23	F0 23	23	F0 23
8	E	Keyboard e and E	19	07	08	12	92	24	F0 24	24	F0 24
9	F	Keyboard f and F	34	07	09	21	A1	2B	F0 2B	2B	F0 2B
10	G	Keyboard g and G	35	07	0A	22	A2	34	F0 34	34	F0 34
11	H	Keyboard h and H	36	07	0B	23	A3	33	F0 33	33	F0 33
12	I	Keyboard i and I	24	07	0C	17	97	43	F0 43	43	F0 43
13	J	Keyboard j and J	37	07	0D	24	A4	3B	F0 3B	3B	F0 3B
14	K	Keyboard k and K	38	07	0E	25	A5	42	F0 42	42	F0 42
15	L	Keyboard l and L	39	07	0F	26	A6	4B	F0 4B	4B	F0 4B
16	M	Keyboard m and M	52	07	10	32	B2	3A	F0 3A	3A	F0 3A
17	N	Keyboard n and N	51	07	11	31	B1	31	F0 31	31	F0 31
18	O	Keyboard o and O	25	07	12	18	98	44	F0 44	44	F0 44
19	P	Keyboard p and P	26	07	13	19	99	4D	F0 4D	4D	F0 4D
20	Q	Keyboard q and Q	17	07	14	10	90	15	F0 15	15	F0 15
21	R	Keyboard r and R	20	07	15	13	93	2D	F0 2D	2D	F0 2D
22	S	Keyboard s and S	32	07	16	1F	9F	1B	F0 1B	1B	F0 1B
23	T	Keyboard t and T	21	07	17	14	94	2C	F0 2C	2C	F0 2C
24	U	Keyboard u and U	23	07	18	16	96	3C	F0 3C	3C	F0 3C
25	V	Keyboard v and V	49	07	19	2F	AF	2A	F0 2A	2A	F0 2A
26	W	Keyboard w and W	18	07	1A	11	91	1D	F0 1D	1D	F0 1D
27	X	Keyboard x and X	47	07	1B	2D	AD	22	F0 22	22	F0 22
28	Y	Keyboard y and Y	22	07	1C	15	95	35	F0 35	35	F0 35
29	Z	Keyboard z and Z	46	07	1D	2C	AC	1A	F0 1A	1A	F0 1A
30	1	Keyboard 1 and !	2	07	1E	02	82	16	F0 16	16	F0 16
31	2	Keyboard 2 and @	3	07	1F	03	83	1E	F0 1E	1E	F0 1E
32	3	Keyboard 3 and #	4	07	20	04	84	26	F0 26	26	F0 26
33	4	Keyboard 4 and \$	5	07	21	05	85	25	F0 25	25	F0 25
34	5	Keyboard 5 and %	6	07	22	06	86	2E	F0 2E	2E	F0 2E
35	6	Keyboard 6 and ^	7	07	23	07	87	36	F0 36	36	F0 36
36	7	Keyboard 7 and &	8	07	24	08	88	3D	F0 3D	3D	F0 3D

## SKey and Scan Code Table – Continued

SKEY (Dec)	Program Code	Description	AT- 101 (Dec)	USB Page (Hex)	USB Usage (Hex)	Set 1 Make (Hex)	Set 1 Break (Hex)	Set 2 Make (Hex)	Set 2 Break (Hex)	Set 3 Make (Hex)	Set 3 Break (Hex)
37	8	Keyboard 8 and *	9	07	25	09	89	3E	F0 3E	3E	F0 3E
38	9	Keyboard 9 and (	10	07	26	0A	8A	46	F0 46	46	F0 46
39	0	Keyboard 0 and )	11	07	27	0B	8B	45	F0 45	45	F0 45
40	ENTER	Keyboard Return(ENTER)	43	07	28	1C	9C	5A	F0 5A	5A	F0 5A
41	ESC	Keyboard ESCAPE	110	07	29	01	81	76	F0 76	08	F0 08
42	BACKSPACE	Keyboard Backspace	15	07	2A	0E	8E	66	F0 66	66	F0 66
43	TAB	Keyboard Tab	16	07	2B	0F	8F	0D	F0 0D	0D	F0 0D
44	SPACE	Keyboard Spacebar	61	07	2C	39	B9	29	F0 29	29	F0 29
45	-/_	Keyboard - and (underscore)	12	07	2D	0C	8C	4E	F0 4E	4E	F0 4E
46	=/+	Keyboard = and+	13	07	2E	0D	8D	55	F0 55	55	F0 55
47	[/{	Keyboard [ and {	27	07	2F	1A	9A	54	F0 54	54	F0 54
48	]}	Keyboard ] and }	28	07	30	1B	9B	5B	F0 5B	5B	F0 5B
49	\	Keyboard \ and	29	07	31	2B	AB	5D	F0 5D	5C	F0 5C
50	KEY42	Keyboard Non-US# and ~	42	07	32	2B	AB	5D	F0 5D	5C	F0 5C
51	;/	Keyboard ; and /	40	07	33	27	A7	4C	F0 4C	4C	F0 4C
52	'"	Keyboard ' and "	41	07	34	28	A8	52	F0 52	52	F0 52
53	~`	Keyboard ~ and `	1	07	35	29	A9	0E	F0 0E	0E	F0 0E
54	,<	Keyboard , and <	53	07	36	33	B3	41	F0 41	41	F0 41
55	.>	Keyboard . and >	54	07	37	34	B4	49	F0 49	49	F0 49
56	/?	Keyboard / and ?	55	07	38	35	B5	4A	F0 4A	4A	F0 4A
57	CAPSLOCK	Keyboard CapsLock	30	07	39	3A	BA	58	F0 58	14	F0 14
58	F1	Keyboard F1	112	07	3A	3B	BB	05	F0 05	07	F0 07
59	F2	Keyboard F2	113	07	3B	3C	BC	06	F0 06	0F	F0 0F
60	F3	Keyboard F3	114	07	3C	3D	BD	04	F0 04	17	F0 17
61	F4	Keyboard F4	115	07	3D	3E	BE	0C	F0 0C	1F	F0 1F
62	F5	Keyboard F5	116	07	3E	3F	BF	03	F0 03	27	F0 27
63	F6	Keyboard F6	117	07	3F	40	C0	0B	F0 0B	2F	F0 2F
64	F7	Keyboard F7	118	07	40	41	C1	83	F0 83	37	F0 37
65	F8	Keyboard F8	119	07	41	42	C2	0A	F0 0A	3F	F0 3F
66	F9	Keyboard F9	120	07	42	43	C3	01	F0 01	47	F0 47
67	F10	Keyboard F10	121	07	43	44	C4	09	F0 09	4F	F0 4F
68	F11	Keyboard F11	122	07	44	57	D7	78	F0 78	56	F0 56
69	F12	Keyboard F12	123	07	45	58	D8	07	F0 07	5E	F0 5E
70	PRINT SCRN	Keyboard PrintScreen	124	07	46	E0 37	E0 B7	E0 7C	E0 F0 7C	57	F0 57
71	SCROLLLOCK	Keyboard ScrollLock	125	07	47	46	C6	7E	F0 7E	5F	F0 5F
72	PAUSE	Keyboard Pause	126	07	48	E1 1D 45 E19D C5	None	E1 14 77 E1 F0 14 F0 77	None	62	F0 62

## SKey and Scan Code Table – Continued

SKEY (Dec)	Program Code	Description	AT-101 (Dec)	USB Page (Hex)	USB Usage (Hex)	Set 1 Make (Hex)	Set 1 Break (Hex)	Set 2 Make (Hex)	Set 2 Break (Hex)	Set 3 Make (Hex)	Set 3 Break (Hex)
72	PUASE	Keyboard Break (Ctrl+Pause)	126	07	48	E0 46 E0 C6	None	E0 7E E0 F0 7E	None	62	F0 62
73	INSERT	Keyboard Insert	75	07	49	E0 52	E0 D2	E0 70	E0 F0 70	67	F0 67
74	HOME	Keyboard Home	80	07	4A	E0 47	E0 C7	E0 6C	E0 F0 6C	6E	F0 6E
75	PAGE UP	Keyboard PageUp	85	07	4B	E0 49	E0 C9	E0 7D	E0 F0 7D	6F	F0 6F
76	DELETE	Keyboard Delete Forward	76	07	4C	E0 53	E0 D3	E0 71	E0 F0 71	64	F0 64
77	END	Keyboard End	81	07	4D	E0 4F	E0 CF	E0 69	E0 F0 69	65	F0 65
78	PAGE DOWN	Keyboard PageDown	86	07	4E	E0 51	E0 D1	E0 7A	E0 F0 7A	6D	F0 6D
79	ARWR	Keyboard RightArrow	89	07	4F	E0 4D	E0 CD	E0 74	E0 F0 74	6A	F0 6A
80	ARWL	Keyboard LeftArrow	79	07	50	E0 4B	E0 CB	E0 6B	E0 F0 6B	61	F0 61
81	ARWDN	Keyboard DownArrow	84	07	51	E0 50	E0 D0	E0 72	E0 F0 72	60	F0 60
82	ARWUP	Keyboard UpArrow	83	07	52	E0 48	E0 C8	E0 75	E0 F0 75	63	F0 63
83	NUMLOCK	Keypad NumLock	90	07	53	45	C5	77	F0 77	76	F0 76
84	N/	Keypad /	95	07	54	E0 35	E0 B5	E0 4A	E0 F0 4A	77	F0 77
85	N*	Keypad *	100	07	55	37	B7	7C	F0 7C	7E	F0 7E
86	N-	Keypad -	105	07	56	4A	CA	7B	F0 7B	84	F0 84
87	N+	Keypad +	106	07	57	4E	CE	79	F0 79	7C	F0 7C
88	NENTER	Keypad ENTER	108	07	58	E0 1C	E0 9C	E0 5A	E0 F0 5A	79	F0 79
89	N1	Keypad 1 and End	93	07	59	4F	CF	69	F0 69	69	F0 69
90	N2	Keypad 2 and Down Arrow	98	07	5A	50	D0	72	F0 72	72	F0 72
91	N3	Keypad 3 and PageDn	103	07	5B	51	D1	7A	F0 7A	7A	F0 7A
92	N4	Keypad 4 and Left Arrow	92	07	5C	4B	CB	6B	F0 6B	6B	F0 6B
93	N5	Keypad 5	97	07	5D	4C	CC	73	F0 73	73	F0 73
94	N6	Keypad 6 and Right Arrow	102	07	5E	4D	CD	74	F0 74	74	F0 74
95	N7	Keypad 7 and Home	91	07	5F	47	C7	6C	F0 6C	6C	F0 6C
96	N8	Keypad 8 and Up Arrow	96	07	60	48	C8	75	F0 75	75	F0 75
97	N9	Keypad 9 and PageUp	101	07	61	49	C9	7D	F0 7D	7D	F0 7D
98	N0	Keypad 0 and Insert	99	07	62	52	D2	70	F0 70	70	F0 70
99	N.	Keypad . and Delete	104	07	63	53	D3	71	F0 71	71	F0 71
100	KEY45	Keyboard Non-US \ and	45	07	64	56	D6	61	F0 61	61	F0 61
101	APPL	Keyboard Application	129	07	65	E0 5D	E0 DD	E0 2F	E0 F0 2F	8D	F0 8D
102	POWER	Keyboard Power	U/A	07	66	E0 5E	E0 DE	E0 37	E0 F0 37	U/A	U/A
103	N=	Keypad =	U/A	07	67	59	D9	0F	F0 0F	U/A	U/A
104	F13	Keyboard F13	U/A	07	68	64	E4	08	F0 08	08	F0 08
105	F14	Keyboard F14	U/A	07	69	65	E5	10	F0 10	10	F0 10
106	F15	Keyboard F15	U/A	07	6A	66	E6	18	F0 18	18	F0 18
107	F16	Keyboard F16	U/A	07	6B	67	E7	20	F0 20	20	F0 20



## SKey and Scan Code Table – Continued

SKEY (Dec)	Program Code	Description	AT- 101 (Dec)	USB Page (Hex)	USB Usage (Hex)	Set 1 Make (Hex)	Set 1 Break (Hex)	Set 2 Make (Hex)	Set 2 Break (Hex)	Set 3 Make (Hex)	Set 3 Break (Hex)
108	F17	Keyboard F17	U/A	07	6C	68	E8	28	F0 28	28	F0 28
109	F18	Keyboard F18	U/A	07	6D	69	E9	30	F0 30	30	F0 30
110	F19	Keyboard F19	U/A	07	6E	6A	EA	38	F0 38	38	F0 38
111	F20	Keyboard F20	U/A	07	6F	6B	EB	40	F0 40	40	F0 40
112	F21	Keyboard F21	U/A	07	70	6C	EC	48	F0 48	48	F0 48
113	F22	Keyboard F22	U/A	07	71	6D	ED	50	F0 50	50	F0 50
114	F23	Keyboard F23	U/A	07	72	6E	EE	57	F0 57	57	F0 57
115	F24	Keyboard F24	U/A	07	73	76	F6	5F	F0 5F	5F	F0 5F
116	LCTRL	Keyboard LeftControl	58	07	E0	1D	9D	14	F0 14	11	F0 11
117	LSHIFT	Keyboard LeftShift	44	07	E1	2A	AA	12	F0 12	12	F0 12
118	LALT	Keyboard LeftAlt	60	07	E2	38	B8	11	F0 11	39	F0 39
119	LWIN	Keyboard Left GUI	127	07	E3	E0 5B	E0 DB	E0 1F	E0 F0 1F	8B	F0 8B
120	RCTRL	Keyboard RightControl	64	07	E4	E0 1D	E0 9D	E0 14	E0 F0 14	58	F0 58
121	RSHIFT	Keyboard RightShift	57	07	E5	36	B6	59	F0 59	59	F0 59
122	RALT	Keyboard RightAlt	62	07	E6	E0 38	E0 B8	E0 11	E0 F0 11	39	F0 39
123	RWIN	Keyboard Right GUI	128	07	E7	E0 5C	E0 DC	E0 27	E0 F0 27	8C	F0 8C
124	SK124	Reserved	U/A	U/A	U/A	U/A	U/A	U/A	U/A	U/A	U/A
125	SK125	Reserved	U/A	U/A	U/A	U/A	U/A	U/A	U/A	U/A	U/A
126	SK126	Reserved	U/A	U/A	U/A	U/A	U/A	U/A	U/A	U/A	U/A
127	SK127	Reserved	U/A	U/A	U/A	U/A	U/A	U/A	U/A	U/A	U/A
128	SK128	Reserved	U/A	U/A	U/A	U/A	U/A	U/A	U/A	U/A	U/A
129	SK129	Reserved	U/A	U/A	U/A	U/A	U/A	U/A	U/A	U/A	U/A
130	SK130	Reserved	U/A	U/A	U/A	U/A	U/A	U/A	U/A	U/A	U/A
131	SK131	Reserved	U/A	U/A	U/A	U/A	U/A	U/A	U/A	U/A	U/A
132	SK132	Reserved	U/A	U/A	U/A	U/A	U/A	U/A	U/A	U/A	U/A
133	KEY107	Keypad, (Brazilian Keypad .)	107	07	85	7E	FE	6D	F0 6D	7B	F0 7B
134	KEY=	Keypad Equal Sign	U/A	07	86	U/A	U/A	U/A	U/A	U/A	U/A
135	INTL1	Keyboard Int'l 1 (Ro)	56	07	87	73	F3	51	F0 51	51	F0 51
136	INTL2	Keyboard Int'l 2 (Katakana/Hiragana)	133	07	88	70	F0	13	F0 13	87	F0 87
137	INTL3	Keyboard Int'l 3 (Yen)	14	07	89	7D	FD	6A	F0 6A	5D	F0 5D
138	INTL4	Keyboard Int'l 4 (Henkan)	132	07	8A	79	F9	64	F0 64	86	F0 86
139	INTL5	Keyboard Int'l 5 (Muhenkan)	131	07	8B	7B	FB	67	F0 67	85	F0 85
140	INTL6	Keyboard Int'l 6 (PC9800 Keypad ,)	U/A	07	8C	5C	DC	27	F0 27	U/A	U/A
141	INTL7	Keyboard Int'l 7	U/A	07	8D	U/A	U/A	U/A	U/A	U/A	U/A
142	INTL8	Keyboard Int'l 8	U/A	07	8E	U/A	U/A	U/A	U/A	U/A	U/A

## SKey and Scan Code Table – Continued

SKEY (Dec)	Program Code	Description	AT-101 (Dec)	USB Page (Hex)	USB Usage (Hex)	Set 1 Make (Hex)	Set 1 Break (Hex)	Set 2 Make (Hex)	Set 2 Break (Hex)	Set 3 Make (Hex)	Set 3 Break (Hex)
143	INTL9	Keyboard Int'l 9	U/A	07	8F	U/A	U/A	U/A	U/A	U/A	U/A
144	LANG1	Keyboard LANG 1 (Hangue/English)	U/A	07	90	F2	None	F2	None	U/A	U/A
145	LANG2	Keyboard LANG 2 (Hanja)	U/A	07	91	F1	None	F1	None	U/A	U/A
146	LANG3	Keyboard LANG 3 (Katakana)	U/A	07	92	78	F8	63	F0 63	U/A	U/A
147	LANG4	Keyboard LANG 4 (Hiragana)	U/A	07	93	77	F7	62	F0 62	U/A	U/A
148	LANG5	Keyboard LANG 5 (Zenkaku/Hankaku)	U/A	07	94	76	F6	5F	F0 5F	U/A	U/A
149	LANG6	Keyboard LANG 6	U/A	07	95	U/A	U/A	U/A	U/A	U/A	U/A
150	LANG7	Keyboard LANG 7	U/A	07	96	U/A	U/A	U/A	U/A	U/A	U/A
151	LANG8	Keyboard LANG 8	U/A	07	97	U/A	U/A	U/A	U/A	U/A	U/A
152	LANG9	Keyboard LANG 9	U/A	07	98	U/A	U/A	U/A	U/A	U/A	U/A
153	PWR	System Power	U/A	01	81	E0 5E	E0 DE	E0 37	E0 F0 37	U/A	U/A
154	SLEEP	System Sleep	U/A	01	82	E0 5F	E0 DF	E0 3F	E0 F0 3F	U/A	U/A
155	WAKE	System Wake Up	U/A	01	83	E0 63	E0 E3	E0 5E	E0 F0 5E	U/A	U/A
156	SK156	Reserved	U/A	U/A	U/A	U/A	U/A	U/A	U/A	U/A	U/A
157	SK157	Reserved	U/A	U/A	U/A	U/A	U/A	U/A	U/A	U/A	U/A
158	LFN	Left FN	U/A	N/A	N/A	N/A	N/A	N/A	N/A	N/A	N/A
159	RFN	Right FN	U/A	N/A	N/A	N/A	N/A	N/A	N/A	N/A	N/A
160	HELP	Help	U/A	0C	0095	U/A	U/A	U/A	U/A	U/A	U/A
161	NXTRK	Scan Next Track	U/A	0C	00B5	E0 19	E0 99	E0 4D	E0 F0 4D	U/A	U/A
162	PVTRK	Scan Previous Track	U/A	0C	00B6	E0 10	E0 90	E0 15	E0 F0 15	U/A	U/A
163	STOP	Stop	U/A	0C	00B7	E0 24	E0 A4	E0 3B	E0 F0 3B	U/A	U/A
164	PLAY	Play/Pause	U/A	0C	00CD	E0 22	E0 A2	E0 34	E0 F0 34	U/A	U/A
165	VOL	Volume	U/A	0C	00E0	U/A	U/A	U/A	U/A	U/A	U/A
166	MUTE	AC Mute	U/A	0C	00E2	E0 20	E0 A0	E0 23	E0 F0 23	U/A	U/A
167	BASS	Bass	U/A	0C	00E3	U/A	U/A	U/A	U/A	U/A	U/A
168	THREBLE	Treble	U/A	0C	00E4	U/A	U/A	U/A	U/A	U/A	U/A
169	BASSBOOST	Bass Boost	U/A	0C	00E5	U/A	U/A	U/A	U/A	U/A	U/A
170	LOUDNESS	Loudness	U/A	0C	00E7	U/A	U/A	U/A	U/A	U/A	U/A
171	VOLDN	Volume Up	U/A	0C	00E9	E0 30	30 B0	E0 32	E0 F0 32	U/A	U/A
172	VOLUP	Volume Down	U/A	0C	00EA	E0 2E	E0 AE	E0 21	E0 F0 21	U/A	U/A
173	BASSUP	Bass Up	U/A	0C	0152	U/A	U/A	U/A	U/A	U/A	U/A

## SKey and Scan Code Table – Continued

SKEY (Dec)	Program Code	Description	AT- 101 (Dec)	USB Page (Hex)	USB Usage (Hex)	Set 1 Make (Hex)	Set 1 Break (Hex)	Set 2 Make (Hex)	Set 2 Break (Hex)	Set 3 Make (Hex)	Set 3 Break (Hex)
174	BASSDN	Bass Down	U/A	0C	0153	U/A	U/A	U/A	U/A	U/A	U/A
175	TREBUP	Treble Up	U/A	0C	0154	U/A	U/A	U/A	U/A	U/A	U/A
176	TREBDN	Treble Down	U/A	0C	0155	U/A	U/A	U/A	U/A	U/A	U/A
177	CCFG	AL Consumer Control Config	U/A	0C	0183	E0 6D	E0 ED	E0 50	E0 F0 50	U/A	U/A
178	WORD	AL Word Processor	U/A	0C	0184	U/A	U/A	U/A	U/A	U/A	U/A
179	SPRD	AL Spreadsheet	U/A	0C	0186	U/A	U/A	U/A	U/A	U/A	U/A
180	EMAIL	AL Email Reader	U/A	0C	018A	E0 6C	E0 EC	E0 48	E0 F0 48	U/A	U/A
181	CALND	AL Calendar	U/A	0C	018E	U/A	U/A	U/A	U/A	U/A	U/A
182	CALC	AL Calculator	U/A	0C	0192	E0 21	E0 A1	E0 2B	E0 F0 2B	U/A	U/A
183	AV	AL AV Capature	U/A	0C	0193	U/A	U/A	U/A	U/A	U/A	U/A
184	LBRWS	AL Local Machine Browser	U/A	0C	0194	E0 6B	E0 EB	E0 40	E0 F0 40	U/A	U/A
185	WBRWS	AL Internet Browser	U/A	0C	0196	U/A	U/A	U/A	U/A	U/A	U/A
186	CHAT	AL Network Chat	U/A	0C	0199	U/A	U/A	U/A	U/A	U/A	U/A
187	LGOFF	AL Logoff	U/A	0C	019C	U/A	U/A	U/A	U/A	U/A	U/A
188	NXAPP	AL Next Task	U/A	0C	01A3	U/A	U/A	U/A	U/A	U/A	U/A
189	PVAPP	AL Previous Task	U/A	0C	01A4	U/A	U/A	U/A	U/A	U/A	U/A
190	SPELL	AL Spell Check	U/A	0C	01AB	U/A	U/A	U/A	U/A	U/A	U/A
191	FBRWS	AL File Browser	U/A	0C	01B4	U/A	U/A	U/A	U/A	U/A	U/A
192	NEW	AC New	U/A	0C	0201	U/A	U/A	U/A	U/A	U/A	U/A
193	OPEN	AC Open	U/A	0C	0202	U/A	U/A	U/A	U/A	U/A	U/A
194	CLOSE	AC Close	U/A	0C	0203	U/A	U/A	U/A	U/A	U/A	U/A
195	SAVE	AC Save	U/A	0C	0207	U/A	U/A	U/A	U/A	U/A	U/A
196	PRINT	AC Print	U/A	0C	0208	U/A	U/A	U/A	U/A	U/A	U/A
197	UNDO	AC Undo	U/A	0C	021A	U/A	U/A	U/A	U/A	U/A	U/A
198	COPY	AC Copy	U/A	0C	021B	U/A	U/A	U/A	U/A	U/A	U/A
199	CUT	AC Cute	U/A	0C	021C	U/A	U/A	U/A	U/A	U/A	U/A
200	PASTE	AC Paste	U/A	0C	021D	U/A	U/A	U/A	U/A	U/A	U/A
201	WSEARCH	AC Search	U/A	0C	0221	E0 65	E0 E5	E0 10	E0 F0 10	U/A	U/A
202	WHOME	AC Home	U/A	0C	0223	E0 32	E0 B2	E0 3A	E0 F0 3A	U/A	U/A
203	WBACK	AC Back	U/A	0C	0224	E0 6A	E0 EA	E0 38	E0 F0 38	U/A	U/A
204	WFDW	AC Forward	U/A	0C	0225	E0 69	E0 E9	E0 30	E0 F0 30	U/A	U/A
205	WSTOP	AC Stop	U/A	0C	0226	E0 68	E0 E8	E0 28	E0 F0 28	U/A	U/A
206	WRFSH	AC Refresh	U/A	0C	0227	E0 67	E0 E7	E0 20	E0 F0 20	U/A	U/A
207	WBKMK	AC Bookmarks	U/A	0C	022A	E0 66	E0 E6	E0 18	E0 F0 18	U/A	U/A
208	REDO	AC Redo/Repeat	U/A	0C	0279	U/A	U/A	U/A	U/A	U/A	U/A
209	REPLY	AC Reply	U/A	0C	0289	U/A	U/A	U/A	U/A	U/A	U/A

## SKey and Scan Code Table – Continued

SKEY (Dec)	Program Code	Description	AT-101 (Dec)	USB Page (Hex)	USB Usage (Hex)	Set 1 Make (Hex)	Set 1 Break (Hex)	Set 2 Make (Hex)	Set 2 Break (Hex)	Set 3 Make (Hex)	Set 3 Break (Hex)
210	MSFWD	AC Forward Message	U/A	0C	028B	U/A	U/A	U/A	U/A	U/A	U/A
211	SEND	AC Send Message	U/A	0C	028C	U/A	U/A	U/A	U/A	U/A	U/A
212	OFFICE	Office	U/A	0C	029D	U/A	U/A	U/A	U/A	U/A	U/A
213	TASK	Task Panel	U/A	0C	029E	U/A	U/A	U/A	U/A	U/A	U/A
214	BLCINC	Backlight Cycle Increase	U/A	U/A	U/A	U/A	U/A	U/A	U/A	U/A	U/A
215	ALERTLED	Alert LED output	U/A	U/A	U/A	U/A	U/A	U/A	U/A	U/A	U/A
216	SOCINC	SOC Cycle Increase	U/A	U/A	U/A	U/A	U/A	U/A	U/A	U/A	U/A
217	GPO0	GPO 0 Level Output	U/A	U/A	U/A	U/A	U/A	U/A	U/A	U/A	U/A
218	GPO1	GPO 1 Level Output	U/A	U/A	U/A	U/A	U/A	U/A	U/A	U/A	U/A
219	BLKOUT	GPO 2 Toggle Output	U/A	U/A	U/A	U/A	U/A	U/A	U/A	U/A	U/A
220	GPO3	GPO 3 Level Output	U/A	U/A	U/A	U/A	U/A	U/A	U/A	U/A	U/A
221	GPO4	GPO 4 Level Output	U/A	U/A	U/A	U/A	U/A	U/A	U/A	U/A	U/A
222	GPO5	GPO 5 Level Output	U/A	U/A	U/A	U/A	U/A	U/A	U/A	U/A	U/A
223	GPO6	GPO 6 Level Output	U/A	U/A	U/A	U/A	U/A	U/A	U/A	U/A	U/A
224	GPO7	GPO 7 Toggle Output	U/A	U/A	U/A	U/A	U/A	U/A	U/A	U/A	U/A
225	LOGIN	LCTRL + LALT + DELETE	U/A	U/A	U/A	U/A	U/A	U/A	U/A	U/A	U/A
226	ALERT	LSHIFT + F1 + ALERTLED	U/A	U/A	U/A	U/A	U/A	U/A	U/A	U/A	U/A
227	SHIFTF2	LSHIFT + F2	U/A	U/A	U/A	U/A	U/A	U/A	U/A	U/A	U/A
228	SHIFTF3	LSHIFT + F3	U/A	U/A	U/A	U/A	U/A	U/A	U/A	U/A	U/A
229	SHIFTF4	LSHIFT + F4	U/A	U/A	U/A	U/A	U/A	U/A	U/A	U/A	U/A
230	CUST_16	KeyMs LBtn	U/A	U/A	U/A	U/A	U/A	U/A	U/A	U/A	U/A
231	CUST_17	KeyMs RBtn	U/A	U/A	U/A	U/A	U/A	U/A	U/A	U/A	U/A
232	CUST_18	KeyMs MBtn	U/A	U/A	U/A	U/A	U/A	U/A	U/A	U/A	U/A
233	CUST_19	KeyMs 4Btn	U/A	U/A	U/A	U/A	U/A	U/A	U/A	U/A	U/A
234	CUST_20	KeyMs 5Bth	U/A	U/A	U/A	U/A	U/A	U/A	U/A	U/A	U/A
235	CUST_21	KeyMs Z Scroll Up	U/A	U/A	U/A	U/A	U/A	U/A	U/A	U/A	U/A
236	CUST_22	KeyMs Z Scroll Down	U/A	U/A	U/A	U/A	U/A	U/A	U/A	U/A	U/A
237	CUST_23	KeyMs XPlus	U/A	U/A	U/A	U/A	U/A	U/A	U/A	U/A	U/A
238	CUST_24	KeyMs XMinus	U/A	U/A	U/A	U/A	U/A	U/A	U/A	U/A	U/A
239	CUST_25	KeyMs YPlus	U/A	U/A	U/A	U/A	U/A	U/A	U/A	U/A	U/A
240	CUST_26	KeyMs YMinus	U/A	U/A	U/A	U/A	U/A	U/A	U/A	U/A	U/A
241	CUST_27	KeyMs XPlus and YPlus	U/A	U/A	U/A	U/A	U/A	U/A	U/A	U/A	U/A
242	CUST_28	KeyMs XMinus and YPlus	U/A	U/A	U/A	U/A	U/A	U/A	U/A	U/A	U/A
243	CUST_29	KeyMs XMinus and YMinus	U/A	U/A	U/A	U/A	U/A	U/A	U/A	U/A	U/A
244	CUST_30	KeyMs XPlus and YMinus	U/A	U/A	U/A	U/A	U/A	U/A	U/A	U/A	U/A
245	CUST_31	KeyMs LBtn Double Click	U/A	U/A	U/A	U/A	U/A	U/A	U/A	U/A	U/A

## SKey and Scan Code Table – Continued

SKEY (Dec)	Program Code	Description	AT- 101 (Dec)	USB Page (Hex)	USB Usage (Hex)	Set 1 Make (Hex)	Set 1 Break (Hex)	Set 2 Make (Hex)	Set 2 Break (Hex)	Set 3 Make (Hex)	Set 3 Break (Hex)
246	00	Key "00"	U/A	U/A	U/A	U/A	U/A	U/A	U/A	U/A	U/A
247	000	Key "000"	U/A	U/A	U/A	U/A	U/A	U/A	U/A	U/A	U/A
248	DELAY0	Delay0	U/A	U/A	U/A	U/A	U/A	U/A	U/A	U/A	U/A
249	DELAY1	Delay1	U/A	U/A	U/A	U/A	U/A	U/A	U/A	U/A	U/A
250	CUST_36	U/A	U/A	U/A	U/A	U/A	U/A	U/A	U/A	U/A	U/A
251	CUST_37	U/A	U/A	U/A	U/A	U/A	U/A	U/A	U/A	U/A	U/A
252	CUST_38	U/A	U/A	U/A	U/A	U/A	U/A	U/A	U/A	U/A	U/A
253	CUST_39	U/A	U/A	U/A	U/A	U/A	U/A	U/A	U/A	U/A	U/A
254	CUST_40	U/A	U/A	U/A	U/A	U/A	U/A	U/A	U/A	U/A	U/A
255	CUST_41	U/A	U/A	U/A	U/A	U/A	U/A	U/A	U/A	U/A	U/A

SCHEMATIC OF EVALUATION BOARD

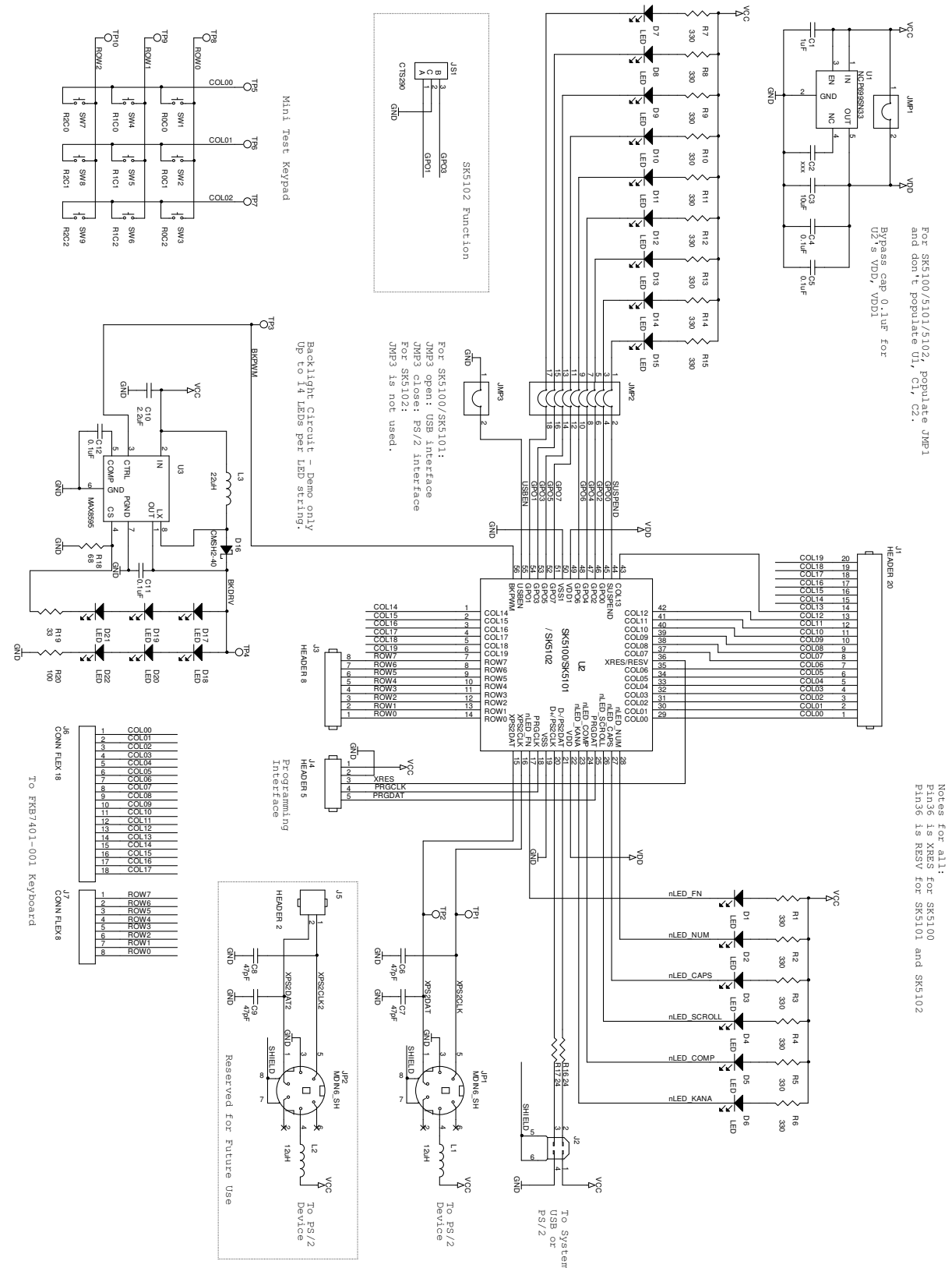

## ELECTRONICS SPECIFICATION

### Absolute Maximum Ratings

Symbol	Description	Min	Typ	Max	Units	Notes
TSTG	Storage Temperature	-55	25	+100	°C	
VDD	Supply Voltage on Relative to VSS	-0.5	-	+6.0	V	
VIO	DC Input Voltage	VSS-0.5	-	VDD+0.5	V	
VIOZ	DC Voltage Applied to Tri-State	VSS-0.5	-	VDD+0.5	V	
IMIO	Maximum Current into any Port Pin	-25	-	+50	mA	
ESD	Electro Static Discharge Voltage	2000	-	-	V	Human Body Model ESD
LU	Latch-up Current	-	-	200	mA	

### Operating Temperature

Symbol	Description	Min	Typ	Max	Units	Notes
TOP	Operating Temperature	0	-	+70	°C	

### DC Electrical Characteristics

Symbol	Description	Min	Typ	Max	Units	Notes
VDD	Supply Voltage	4.57	-	+5.25	V	
IDD	Supply Current when IC is in operation mode		18		Ma	
ISD	Supply Current when IC is in suspend mode without AB rotary encoder enabled		230		Ua	
ISD2	Supply Current when IC is in suspend mode with AB rotary encoder enabled		380		Ua	
RPU	Pull-up Resistor	4	5.6	8	K $\omega$	
VOH	High Output Level	VDD-1.0	-	-	V	
VOL	Low Output Level	-	-	0.75	V	
VIL	Input Low Level	-	-	0.8	V	
VIH	Input High Level	2.1	-	-	V	
VIL	Input Leakage Current (Absolute Value)	-	1	-	Na	
LVD	Low voltage Detection	4.39	4.48	4.57	V	

**PACKAGING INFORMATION**

**SK5102-LT Drawing**

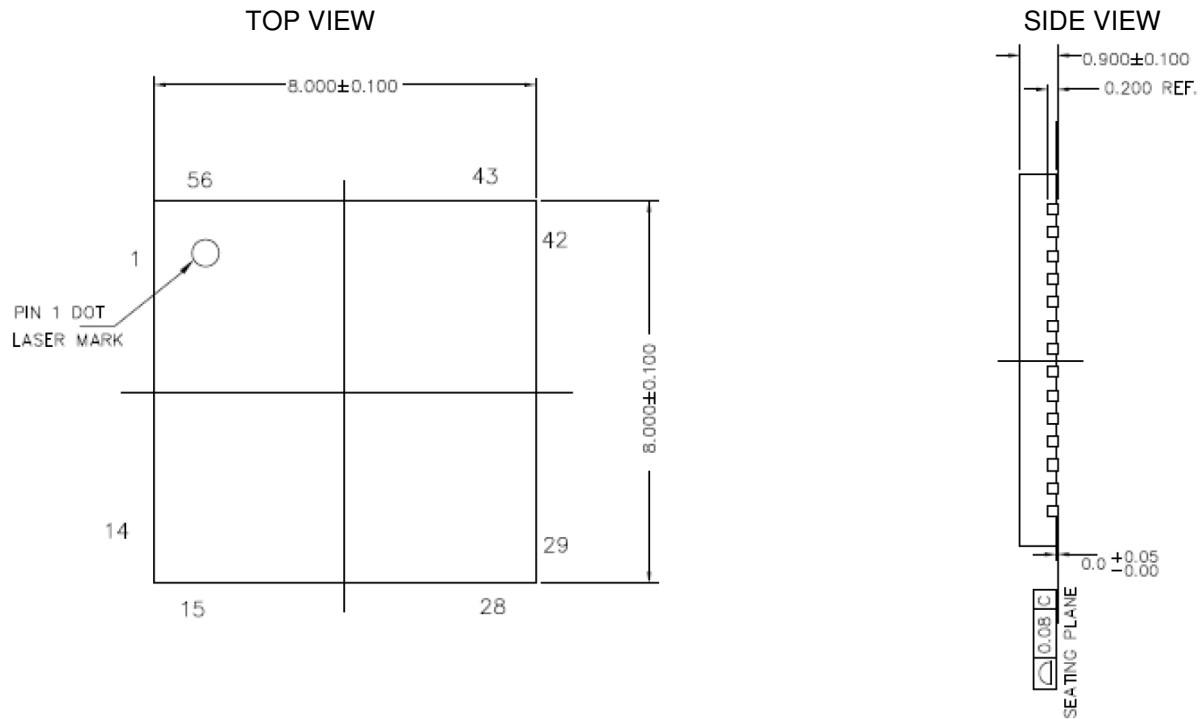

NOTES:

DIMENSION IN mm[Inches]  $\frac{\text{MIN}}{\text{MAX}}$

**SK5102-LT 56-Lead (8x8mm 1.0 MAX) Saw QFN**



**Assembly Specification**

Part	Description	Min	Typ	Max	Units	Notes
$\Theta_{ja}$	Thermal Impedance		20		$^{\circ}\text{C}/\text{W}$	$T_J = T_A + \text{POWER} \times \Theta_{ja}$ To achieve the thermal impedance, the center thermal pad should be soldered to the PCB ground plane.
SRPT	Solder Reflow Peak Temperature	240*	-	260	$^{\circ}\text{C}$	*Higher temperatures may be required based on the solder melting point. Typical temperatures for solder are $220 \pm 5^{\circ}\text{C}$ with Sn-Pb or $245 \pm 5^{\circ}\text{C}$ with Sn-Ag-Cu paste. Refer to the solder manufacturer specifications.
MSL	Moisture Sensitivity Level		MSL3			
WEIGHT	Package Weight		0.126		g	

## SALE AND SERVICE INFORMATION

To obtain information about Sprintek Corporation or FlexMatrix keyboard controller family sales and technical support, reference the following information.

### Sprintek Corporation

4969 Corral St.

Simi Valley, CA 93063, USA

Phone: 805.405.8787

Web Site: <http://www.sprintek.com>

## REVISION HISTORY

Revision	Issue Date	Description
1.00	February 11, 2009	Initial Release
1.01	April 5, 2009	Added assembly specification.
1.02	October 12, 2009	Added "00", "000" key into key table; updated evk schematic; changed LVD voltage to 4.48V.
1.03	October 1, 2010	Added SK5102-LT Saw QFN56 part; obsolete SK5102-LF QFN56 part; company address changed.
1.04	July 15, 2011	Added SK5102 V1.02's new features. Delay0, Delay1, ExtMacro, Independent RFN, N-key rollover via diode, 3 types of rotary encoders. Removed SK5102-LF information.